

# T Level Technical Qualification in Building Services Engineering for Construction

## Refrigeration Engineering (8710-38) (358)

### Assessor pack

**Practical Assignment 2020 – Sample**

Version and date	Change detail	Section
1.1 Jan 2021	Minor amendment to Band 1 descriptor	Marking Grid (Health and Safety)
1.2 May 2021	Minor amendment to pass grade descriptor	Grade descriptors.
	Update to assessor guidance for: Task 1 - tolerance specified for calculation result. Task 3 – What must be produced for marking: report on safe isolation removed  Photographic evidence requirements updated (tasks 3 and 4)	Task specific guidance
	Marking grid for calculations updated to account for tolerances.	Marking Grid (Design & Planning)
1.3 June 2021	Update to assessor guidance for Task 1 – tolerance shown as +/- percentage and kW value.	Task specific guidance
	Marking grid for calculations updated to state % tolerance.	Marking Grid (Design & Planning)

## **Contents**

---

### **Assessment** **4**

Performance outcomes 5

Grade descriptors 6

Assignment Brief 7

Tasks 10

Task-specific guidance 12

Task 1 – Design 12

Task 2 – Planning the installation 13

Task 3 – Install and commission 14

Task 4 – Service and maintenance 18

---

### **Centre guidance** **22**

---

### **Marking grid guidance** **29**

Marking grid 31

---

### **Links to English, Maths and Digital skills** **49**

---

## Assessment

The assessment for this component consists of a practical assignment that includes a project brief and several tasks for the candidate to complete. The tasks set produce assessment themes that cover a range of knowledge and skills from the performance outcomes in the qualification specification. They are designed to allow judgement of the candidate to be made across different categories of performance.

The assessment for this component has been allocated a set number of marks against each task, based on weightings recommended by stakeholders of the qualification. This mark allocation remains the same for all versions of the assessments, ensuring consistency across assessment versions and over time.

## Performance outcomes

The weightings for each performance outcome (PO) will remain the same for every version of the practical assignment. This ensures the appropriate depth and breadth of knowledge and skills for each specialism can be reliably assessed in every version and meets the needs of industry while keeping comparability between each assessment over time.

Performance outcome	Typical Knowledge and skills	Weighting
Install refrigeration systems	Displays a breadth of knowledge and practical skills that enables them to complete the given installation tasks successfully. Has the technical skills to use tools and materials safely and in logical order in relation to a plan.	37%
Commission refrigeration systems	Working in a safe manner, carrying out testing and interpreting test results, use of tools and equipment, use of diagnostic equipment, working with documentation (manufacturer's instructions, building regulations), carrying out tasks in clear and logical sequence, carrying out clear record keeping of test result.	23%
Maintain refrigeration systems	Applying knowledge and understanding through practical skills to solve a particular scenario/problem – justifying decisions/approaches taken e.g. materials, techniques, appropriate protection of customer property and effective use of materials, consideration of costs and impacts to environment.	40%

## **Grade descriptors**

### **To achieve a pass (threshold competence), a candidate will be able to:**

Demonstrate an acceptable performance that meets the requirement of the brief and that is required to enter the industry to begin to work in the occupational area.

Demonstrate the adequate technical skills in cutting, bending, fixing pipework and installing components that is in line with industry standards.

Interpret information, demonstrate planning, assess risk and follow safe working methods when applying practical skills to an acceptable standard as recognised by industry.

Demonstrate basic knowledge and understanding of the principles and processes required for refrigeration engineering.

Work safely showing an understanding in the selection and use of tools and equipment and demonstrate a basic awareness of straightforward preparation and application processes.

Attempt some complex tasks and the level of performance mostly meets an acceptable level.

Identify routine causes of refrigeration faults and have some knowledge in how to rectify them.

Use industrial terminology most of the time that is accurate in both written and verbal contexts.

### **To achieve a distinction, a candidate will be able to:**

Demonstrate an exemplary performance that fully meets the requirement of the brief and is able to enter the industry to begin to work in the occupational area.

Demonstrate exemplary technical skills in cutting, bending, fixing pipework and installing components that is in line with industry standards.

Demonstrate relevant and comprehensive knowledge and understanding of refrigeration principles and processes through the tasks completed.

Work safely showing an understanding in the selection and use of tools and equipment and demonstrates an advanced awareness of straightforward preparation and application processes.

Solution-focused, confidently attempting to diagnose complex tasks and faults in refrigeration. They will be able to accurately research, identify and rectify issues independently.

Consistently uses industry terminology in both written and verbal contexts.

## Assignment Brief

You have been called to a property to undertake the design, planning and installation of a refrigeration system to a pre-existing freezer room.

Your supervisor (assessor) has asked you to carry out a survey of the proposed installation.

The customer has identified the wall space that they want to locate the cooler on and the outdoor area to site the condensing unit.

The general layout of the installation is shown in **Figure 1** and **Figure 2**.

The power supply will be taken from a local isolator provided by others.

Condensate drainage will be connected to the main drain line provided by others.

Your supervisor (assessor) will notify you of the requirements of the installation and a plan of the proposed space and location of existing services where you will carry out the installation.

Whilst on site, the customer asked for an inspection of a faulty refrigeration system at the same property. After inspection, it has been identified that it requires a compressor change and a routine maintenance. You are required to discuss this with the customer and agree to carry out this work.

This assignment has a time of 28 hours. Plan your time accordingly to enable timely completion.

**Figure 1 – Refrigeration schematic component layout.**

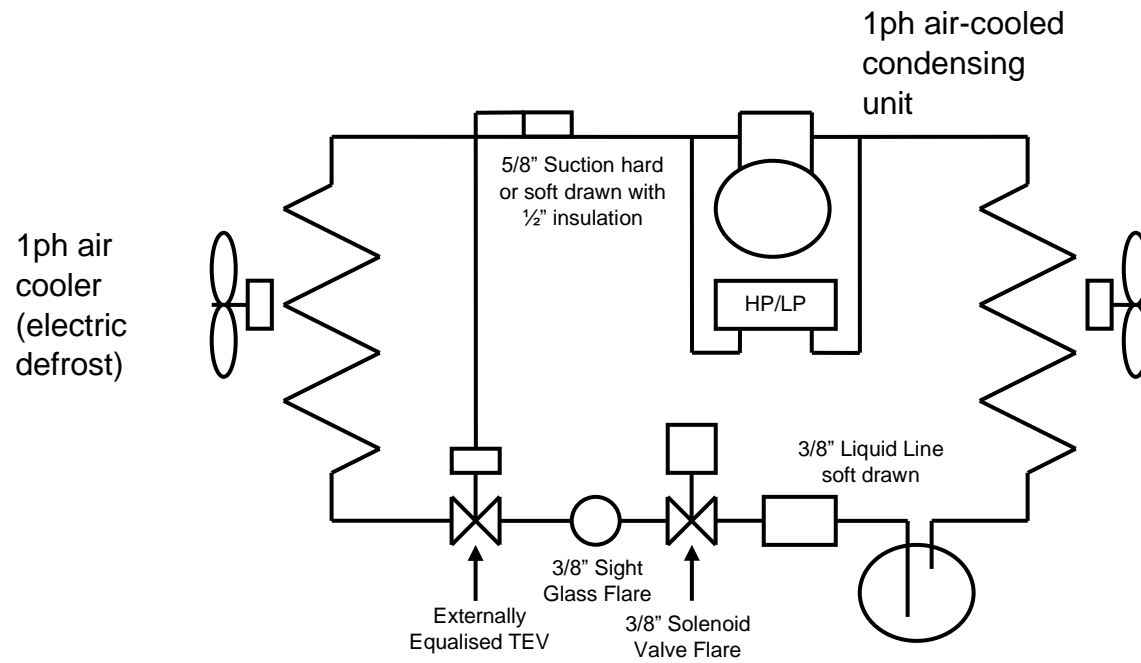



# Figure 2 Refrigeration System Installation layout.

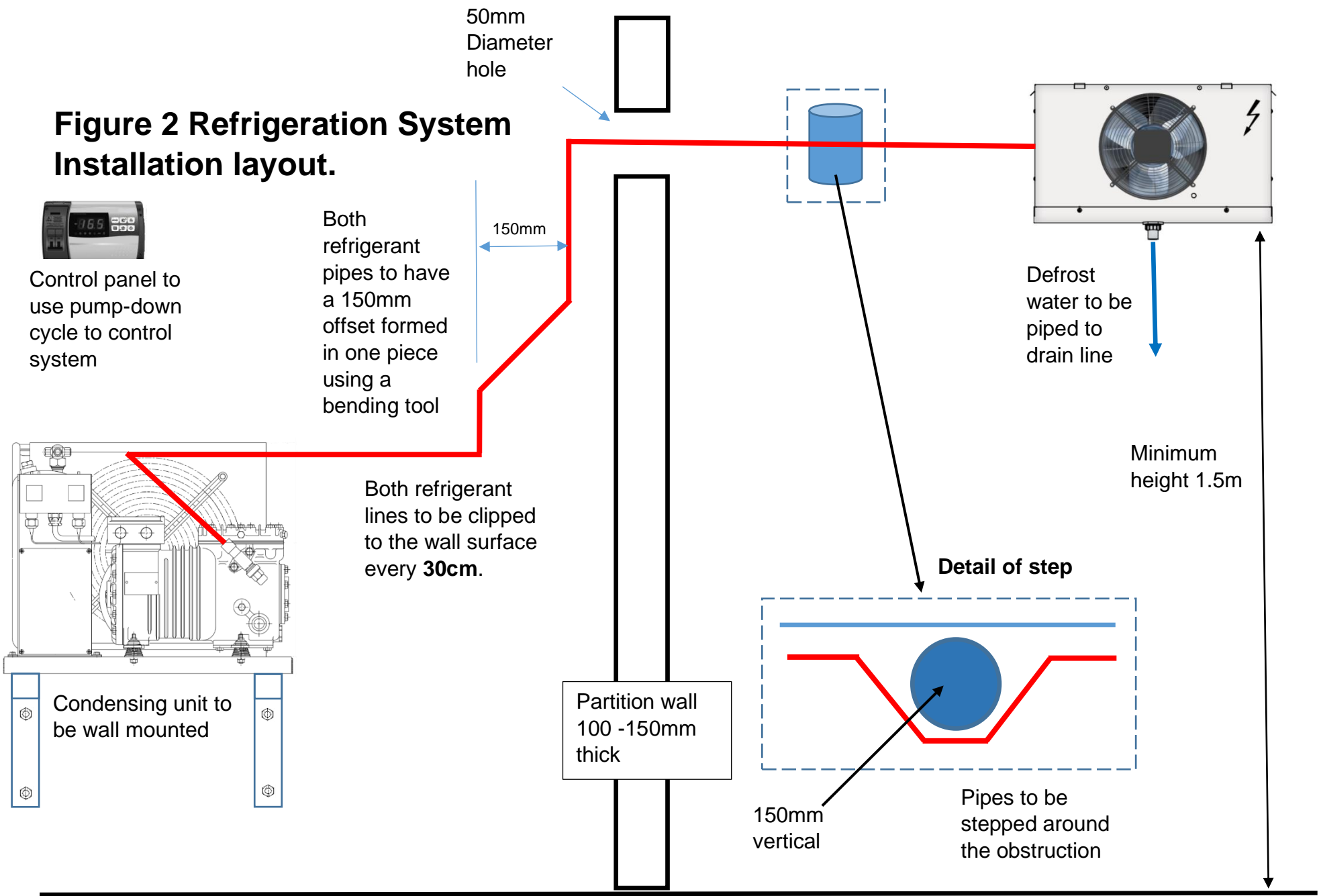

## Tasks

Please read **ALL** information carefully before the assessment.

Ensure you have read the following guidance before you undertake the assessment of candidates:

- T level technical qualifications – marking
- T level technical qualifications – moderation (updated annually)
- T level technical qualifications – teaching, learning and assessment
- Technical qualification guides on marking and moderation
- Practical Observation template
- Mark grids following the tasks below
- Feedback guidance for assessors.

### General task guidance

Centres must meet the specification given in **Figure 1** as a minimum and provide a 0.4kW ( $\frac{1}{2}$  HP) cold room refrigeration system suitable for a 230V AC power supply. If they are unable to implement or facilitate this specification, they must contact City & Guilds.

All work carried out should be to industry standards, done in a safe manner and compliant with building regulations. If a candidate fails to carry out the activities in a safe manner, the assignment should be suspended until this aspect is corrected.

Photographs must be used to support the qualitative statements captured on the PO form. Details of specific photograph requirements are outlined in the task information below. Photographs must have the date and candidate's name attached so that they can be differentiated. The candidate does not need to be in the photograph, the purpose of the photograph is to demonstrate the quality and standards of work of specific activities and of the work throughout various stages of the assignment.

### Time

The time allocated for the completion of the tasks and production of evidence for this assessment is 28 hours. Timings for completion of specific tasks are outlined below.

- Task 1 – 2 hours
  - Task 2 – 3 hours
  - Task 3 – 15 hours
  - Task 4 – 8 hours.
-

## Resources

Candidates must have access to a suitable range of resources to carry out the tasks and, where appropriate, to have the opportunity to choose materials demonstrating the ability to select from a range of appropriate materials.

Candidates should have access to a range of the following:

- Refrigeration specialist tools (tube cutters, pipe benders, swaging tools etc)
- Suitable refrigeration-grade soft-rolled copper pipe and electrical cable
- Brazing equipment and consumables
- Nitrogen pressure testing and purging equipment
- Vacuum pump and vacuum gauge
- Refrigerant and charging equipment
- Test equipment (multi-meter, thermometers etc)
- PPE
- Manufacturer's instructions for all equipment must be available.

The assessment area must also contain the following:

- Suitable 230V AC mains isolator
- Drain point for condensate water connection.

## Task-specific guidance

### Task 1 – Design

#### Resources

Calculator

Answer sheet

#### Assessor guidance

##### Heat ingress

$$\text{Walls} : 17 \times 3.2 \times 0.19 \times 52 = 537.472\text{W}$$

$$\text{Floor: } (5 \times 3.5) \times 0.25 \times 35 = 153.125\text{W}$$

$$\text{Roof: } (5 \times 3.5) \times 0.15 \times 52 = 136.5\text{W}$$

$$\text{Total heat ingress} = \underline{\underline{827.097\text{W}}}$$

##### Product heat load

$$Q_{\text{saf}} = 500 \times 3.2 \times (5 - 2^\circ\text{C}) = 11200\text{kJ}$$

$$Q_{\text{I}} = 500 \times 230 = 115000\text{kJ}$$

$$Q_{\text{sbf}} = 500 \times 1.7 \times (-2 - -20^\circ\text{C}) = 15300\text{kJ}$$

$$\text{Total heat} = 11200 + 115000 + 15300 = \mathbf{141500\text{kJ}}$$

$$\text{Heat load} = 141500 / (8 \times 3600) = 4.91\text{kW} = \underline{\underline{4910\text{W}}}$$

##### Additional heat loads

$$\text{Floor heater} = (5 \times 3.5) \times 15 = 262.5\text{W}$$

$$\text{Lighting } 300 \times 8/24 = 100\text{W}$$

$$\text{Door heater} = 50\text{W}$$

$$\text{Fan motors} = (3 \times 550) \times 23 / 24 = 1581.25\text{W}$$

$$\text{Defrost heater} = 5000 \times 1/24 = 208.33\text{W}$$

$$\text{Occupancy} = 230\text{W} \times 2 \times 4/24 = 76.7\text{W}$$

$$\text{Total additional loads} = \mathbf{2278.74\text{kW}}$$

$$\underline{\underline{\text{Total heat load}}} = 827.097 + 4910 + 2278.74 = 8015.837\text{W} = \underline{\underline{\mathbf{8kW}}}$$

Overall calculation result should be within an expected tolerance of +/- 6.25% (0.5 kW) of the total heat load.

## Task 2 – Planning the installation

Task 2 assesses the candidate's ability to carry out a full installation of a refrigeration system as per the schematic and general assembly drawing given in the candidate pack.

### Resources

Suitable installation booth approximately 1.8m L x 1.8m W x 2.2m high complete with dividing wall and 50mm diameter hole at high level (above nominal finished ceiling level).

Tape measure

Drawing materials

Blank risk assessment and method statement templates.

### Assessor Guidance

#### a) Plan the installation of the refrigeration system as per Figures 1 and 2.

The candidate is to produce a detailed and dimensioned plan of the installation, conforming to the requirements of Figures 1 and 2. This will be used by the candidate to carry out the installation and will also be used by the assessor for checking the dimensional tolerances of the installed system and pipework.

The candidate will also produce a detailed risk assessment(s), method statement(s), materials, tools and PPE lists for the whole installation and the service and maintenance task (Task 2 and 3) and should be encouraged to revise both documents if issues encountered during the installation need a change of plan. The risk assessments and method statement must contain justifications for the methods and actions to be employed.

#### b) Measure and mark out work area as detailed in your plan.

### Conditions of assessment:

- The time allocated for this task is 3 hours.
- Candidates must carry out the task on their own, under controlled conditions.

### What must be produced for marking:

- Scaled installation plan showing all location dimensions of indoor and outdoor units and pipe route
- Risk assessment
- Method statement
- Materials List
- Tools list
- PPE list.

## **Task 3 – Install and commission**

### **Resources for installation and commissioning**

#### **Tools**

Selection of suitable hand tools (screwdrivers, spanners and Allen keys)

Tube cutters and swaging equipment

Power tools for drilling and fixing

Dust sheets and heat protection mats

Heat producing equipment suitable for the brazing of copper pipe

5/8" and 3/8" pipe benders

Heat producing equipment suitable for brazing copper pipe

Vacuum pump and vacuum gauge

Refrigerant weighing scales

Gauge manifold

Cylinder of refrigerant gas

Multimeter

Thermometer with air and contact probes.

#### **Materials**

0.4kW (½ HP) refrigeration condensing unit and matched cold room cooler

Thermostatic expansion valve

3/8" solenoid valve

3/8" Drier

3/8" sight glass

2 rolls soft-drawn copper pipe (nominally 5/8" and 3/8" OD) approximately 5m long

5/8" and 3/8" ID pipe insulation material

5/8" and 3/8" wall mounted insulated pipe brackets

Plastic pipework trunking and accessories

Selection of fixings for pipe brackets and indoor and outdoor units.

## Assessor guidance

The assessor must observe all electrical and pressure testing.

### **a) Carry out the installation of the refrigeration system in accordance with your drawing and as agreed by your assessor.**

The system is to be given to the candidate fully **decommissioned (empty** of refrigerant gas), so the candidate is able to pressure test both the cooler and condenser and then charge the system with a weighed refrigerant charge as per manufacturer's requirements.

Candidates must have access to their drawing and plans from **Task 1**.

Candidate is required to carry out the installation of the refrigeration system and associated pipework in accordance with their drawing and as agreed by you.

All pipework is to be clipped directly to the wall surface (cable tray must **NOT** be used) with the pipe brackets at a maximum **300mm spacing**.

Both pipes should be at **50mm** centres.

All pipe bends must be carried out with the correct size pipe bending tool.

**Nitrogen purging** is to be carried out during all brazing activities.

Marking out and final measuring of installed components and pipework is to be within **+/- 2mm**.

All internal pipework below the notional finished ceiling level is to be contained with suitable plastic trunking.

Outlet pipe from condensate pump is to be terminated to a suitable waste water drain line.

### **b) All pipework is to be pressure tested (strength and tightness).**

On completion of pipework, the correct strength and tightness test pressures must be calculated by the candidate in accordance with current F-Gas regulations and BS EN378.

Candidate will then carry out strength and tightness testing of system and pipework under the direct observation of the assessor. Leak checking will be conducted with either a soap solution or proprietary leak testing fluid. Tightness test will be held for a minimum of **one hour**.

Candidate will complete the pressure test certificate provided in the resource pack and countersigned by the assessor.

### **c) Connect the electrical supply and interconnecting wiring to the refrigeration system and condensate pump from a suitably supplied electrical isolator and provide a written account of the safe isolation process.**

Candidates must connect the electrical supply to the refrigeration system from a suitably supplied isolator and provide a written account of the safe isolation process.

The safe isolation procedure should be followed and directly observed.

All power, interconnecting and control wiring must be in accordance with manufacturer's requirements and meet current UK regulations.

#### **d) Commission the system**

After pressure and leak testing, the system will be evacuated to 2 Torr minimum, with the final vacuum checked by the assessor using a vacuum gauge.

Vacuum pump to be capable of evacuating the system down to 2 Torr or 2000 Microns.

Vacuum gauge to be able to read and indicate to 2 Torr or 2000 Microns.

Candidate will then weigh-in the correct refrigerant charge as specified by the manufacturer.

The system will then be commissioned as per the commissioning document provided in the resource pack with all the data recorded in full.

#### **e) Once commissioning is complete you are required to handover to customer.**

After commissioning and testing the candidate will remove the gauges from the system, minimising the loss of refrigerant to the atmosphere, and conduct a final leak check.

They will then handover the refrigeration system to the client.

The handover to client must include:

- Demonstration of operation
- Routine maintenance requirements
- Removal and cleaning of air filters.

The assessor will act as the client during the handover

#### **Conditions of assessment:**

- The time allocated for this task is 15 hours
- Candidates must carry out the task on their own, under controlled conditions.

#### **What must be produced for marking that marks will be awarded for:**

- Completed installation
- Pressure test certificate
- Commissioning checklist
- Hand over the system to the client.

#### **Additional evidence for this task:**

Assessor observations must include:

Observation – Safe isolation

- Safe isolation process.



### Observation – Installation of systems and components

- Measuring and marking out
- Installation of pipe and components
- Measurements of pipe and components are within tolerance of +/- 2mm.
- Safe use of nitrogen cylinder and equipment to pressure test the system
- Evacuation and charging of system.

### Observation – Commission and handover system

- Commissioning and data collection and setting controls
- Handover to client

To support the comments made within the practical observation form, the following photographic evidence should be uploaded as a minimum for each candidate:

#### **Installation**

- Photograph of the offset conforming to the 150mm dimension. – demonstrates that the candidate can bend pipe accurately to a tolerance.
- Photograph showing the offset around the soil pipe obstruction – demonstrates the candidate's pipework skills forming bend around the soil pipe.
- Photograph of installed components where the condensing and cooling unit match the installation drawing. This photo demonstrates the candidate's ability to install components to a +/- 5mm tolerance.
- Four to six photographs of each brazed joint – Demonstrates how well the joint is finished.
- Two photos one each side of the wall showing finished pipework (without insulation). This demonstrates the aesthetics of the completed installation.

#### **Commissioning**

Photographic evidence showing the correct use, layout and connection of equipment to perform:

- Evacuation and vacuum gauge reading
- Weighing in the refrigerant charge
- Visual inspection of system and pipework and measurement of temperature.

## Task 4 – Service and maintenance

### Resources

Three compressors for fault finding purposes:

- One to have an earth fault
- One to have winding open circuit
- One to have no fault.

Charged refrigeration system - Compressor change (as this unit is not to be run it can be a redundant unit)

Complete operational nominal refrigeration system - Maintenance activity

Manifold gauges

Selection of hand tools (screwdrivers, spanners, Allen keys)

Recovery unit and cylinder

Refrigerant weighing scales

Tube cutters and swaging equipment

Power tools for drilling and fixing

Dust sheets and heat protection mats

Heat producing equipment suitable for the brazing of copper pipe

3/8" and 1/4" pipe benders

Heat producing equipment suitable for brazing copper pipe

Vacuum pump and vacuum gauge.

Cylinder of refrigerant gas

Multimeter

Insulation resistance tester

Proprietary coil cleaning fluid

Suitable spray washer

Cleaning materials.

Thermometer with air and contact probes.

Anemometer

Electronic leak detector (or proprietary leak testing fluid)

## Assessor guidance

### a) Diagnose faults

The first part of the task is fault finding; the candidate will be given three compressors and will need to select the appropriate tools and testing devices to determine which compressor:

- Is down to earth
- Has an open circuit winding
- Has no fault at all.

### b) Replace and refit compressor as agreed by the assessor

Carry out a compressor change on a refrigeration system. A low-cost bottle cooler, water cooler or similar would be sufficient. The candidate will be expected to recover the refrigerant to atmospheric pressure or below, un-braze the compressor and remove it from the condensing unit.

The candidate will then refit and re-braze the compressor into the condensing unit.

It will then be pressure tested according to F-Gas regulations and BS EN378 and leak tested.

Pressure test will be held and observed for a minimum of one hour.

System will then be evacuated to 2 Torr minimum and charged with weighed amount of refrigerant according to manufacturer's requirements.

### c) Carry out routine maintenance on a refrigeration system.

The final part of assessment will require the candidate to perform a routine maintenance on an operational refrigeration system.

The candidate will first carry out a safe electrical isolation procedure to shut the system down.

They will then mix, and spray clean the evaporator and condenser coils using a proprietary coil cleaning fluid.

The candidate will then leak test the entire system with either an electronic leak detector or soap solution.

On completion of cleaning and leak testing, the candidate will run and test the system (no requirement to fit gauges) and record the readings.

The candidate will then hand the system over to the client and explain what they have done.

The assessor acting, as the client during the handover, will then provide feedback on candidate performance.

**d) Produce a service and maintenance report to include details of the fault, methods for repair and chosen method of repair with reasoning.**

The candidate will then also complete the following documentation.

- Pressure test certificate
- F-Gas log sheet
- Waste transfer note.

**Conditions of assessment:**

- The time allocated for this task is 8 hours
- Candidates must carry out the task on their own, under controlled conditions.

**What must be produced for marking:**

- Pressure test certificate signed by candidate and assessor
- F-Gas log sheet
- Job sheet
- Waste Transfer note.

**Additional evidence for this task:**

On completion of the compressor change, there must be no sign of heat damage to the interior or exterior of the condensing unit and the unit must have all its panels fitted and screwed on correctly.

On completion of the maintenance task, the system must be running at the correct temperature and all parts clean and tidy.

On completion of the maintenance task, the system must be running at the correct temperature and all parts clean and tidy.

Practical observation reports on the candidate's compressor change and maintenance activity specifically focusing on the use of tools and heat producing equipment to remove the compressor with minimal damage, safe isolation procedure, removal and cleaning of air filter, cleaning of coils, leak testing of system, run and testing of temperatures and airflows.

Observation: Fault diagnosis

- Correct use of electrical test instruments
- Correct identification of compressor faults.

Observation: Decommissioning

- Correct set up of recovery equipment
- Cylinder suitability and contents checked
- Recovery of refrigerant.

Observation: Safe isolation

- Safe isolation process.

Observation: Fault rectification

- Removal of compressor using heat producing equipment
- Protection of other components/surrounding components
- Installation of replacement compressor
- Safe use of nitrogen cylinder and equipment to pressure test the system
- Evacuation and charging of system
- Test compressor meets operating specifications.

To support the comments made within the practical observation form the following photographic evidence should be uploaded as a minimum for each candidate:

Compressor Change (a photograph for each of the below)

- Disassembly of condensing unit demonstrating any damage, or no damage caused
- Un-brazing and removal of compressor demonstrating damage, or no damage
- Refitting and brazing of compressor showing damage, or no damage
- Set up of pressure testing equipment and gauge reading
- Leak testing to show correct safety procedures including PPE and correct fluid/device
- Evacuation to 2 Torr – set up of equipment and gauge reading
- Charging of system – set up of equipment
- Final reassembly of condensing unit showing either no damage or damage caused.

Maintenance (a photograph for each of the below)

- Removal and cleaning of air filter
- Cleaning of coils (use of spray washer)
- Leak testing of system
- Run and testing of temperatures and air flows

## Centre guidance

Guidance provided in this document supports the administration of this project.

The following documents, available on the City & Guilds website, provide essential generic guidance for centres delivering Technical qualifications and **must** be referred to alongside this guidance:

- ***T level technical qualifications – marking***
- ***T level technical qualifications – moderation (updated annually)***
- ***T level technical qualifications – teaching, learning and assessment.***

This synoptic assessment is designed to require the candidate to make use of their core knowledge, understanding and the practical skills they have built up over the course of their learning to tackle tasks/problems/challenges.

This approach to assessment emphasises to candidates the importance and applicability of the full range of their learning to practice in their industry area and supports them in learning to take responsibility for transferring their knowledge, understanding and skills to the practical situation, fostering independence, autonomy and confidence.

Candidates are provided with an assignment brief. They then have to draw on their knowledge and skills and independently select the correct processes, tools, equipment, materials and approaches to take, to complete the brief.

During the learning programme, it is expected that tutors will have taken the opportunity to set shorter, formative tasks that allow candidates to be supported to independently use the learning they have so far covered, drawing this together in a similar way, so they are familiar with the format, conditions and expectations of the synoptic assessment.

Candidates should be made aware during learning what the assessment themes are and how they are implemented in marking the assignment, so they will understand the level of performance that will achieve them high marks.

Candidates should not be entered for the assessment until the end of the course of learning for the qualification, so they are in a position to complete the assignment successfully.

### **Health and safety**

Candidates must not be entered for assessment without being clear of the importance of working safely and having attended sufficient practical training to be able to work safely. The assessor must immediately stop an assessment if a candidate works unsafely. At the discretion of the assessor, depending on the severity of the incident, the candidate may be given a warning. If they continue to work unsafely, risking the safety of themselves or others, however, their assessment must be ended, and they must retake the assessment in a future series after significant further training has taken place.

### **Compliance with timings**

Due to the nature of this assessment, the maximum time allowances provided must be adhered to. They refer directly to assessment time, not any additional setting up or drying times the centre needs to create an appropriate assessment environment.

It is the centre's responsibility to plan sufficient assessment sessions, under the appropriate conditions, within the assignment window, to allow candidates reasonable time to complete the assessment tasks.

Where candidates are required to plan their work, they should have their plans confirmed for appropriateness in relation to the time allocated for each task.

Candidates should be allowed sufficient time to fully demonstrate the range of their skills, however this also needs to be reasonable and practicable. Candidates should be allowed to overrun their planned timings or professional service times (where they exist) in order for evidence of a range of their skills to be captured. If however, the time required exceeds reasonably set assessment periods, or the tolerance suggested for professional service times, the centre may stop the assessment and base the marking on the evidence up to that point, including the tutor's notes of how far over time the task has taken.

### **Assessor candidate ratios**

The number of candidates a tutor will be able to observe at one time will vary depending on:

- the complexity of evidence collection for the task
- local conditions e.g. layout of the assessment environment
- amount of additional support available (e.g. to capture image/video evidence), staggered starts etc
- whether there are any peak times where there is a lot of evidence to collect that will need additional support or any that are quieter.

It is advisable to trial the planned arrangements where possible during formative assessment, reviewing the quality of evidence captured and manageability. It is expected that for straight forward observations, (and unless otherwise specified) no more than six candidates will be observed by a single tutor at one time, and the number will usually be fewer than this maximum. The key factor to consider is the logistics of collecting sufficient evidence.

As far as possible, candidates should not be distracted, or their performance affected by the process of observation and evidence collection.

### **Observation evidence**

Observation notes form part of the candidate's evidence and must capture evidence of candidate performance during the practical tasks, describing how well the activity has been carried out, rather than stating the steps/actions the candidate has taken. The notes must be very descriptive and focus on the quality of the performance that are notable in relation to the quality indicators in the marking grid. They must provide sufficient, appropriate evidence that can be used by the assessor (and moderator) to mark the performance using the marking grid. These descriptions will be used, along with e.g. photographic and video evidence to choose the relevant marking band and mark within the band so that candidates can be reliably and validly differentiated based on their performance. Observation evidence captured in these forms must give the necessary information to enable the final assessment of the task at a later date. This is to allow a holistic judgement to be carried out after all evidence for the task is available, at which point full consideration of how the candidate has applied both their skills and their knowledge during the practical can be given.

Identifying what it is about the performances that is different between candidates can clarify the qualities that are important to record. Each candidate is likely to carry out the same steps, so a

checklist of this information would not help differentiate between them. However, qualitative comments on how well they do it, and quantitative records of accuracy and tolerances would.

The tutor should refer to the marking grid to ensure appropriate aspects of performance are recorded. These notes will be used for marking and moderation purposes and so must be detailed, accurate and differentiating.

Tutors should ensure that any required additional supporting evidence including e.g. photographs or video can be easily matched to the correct candidate, are clear, well-lit and showing the areas of particular interest in sufficient detail and clarity for assessment (i.e. taken at appropriate points in production, showing accuracy of measurements where appropriate).

If candidates are required to work as a team, each candidate's contribution must be noted separately. The tutor may intervene if any individual candidate's contribution is unclear or to ensure fair access (see below).

Assessor marking and justification is completed on a separate form (CRF) to differentiate this evidence from the judgement, since in some cases the observation form will provide evidence relating to the judgement for more than one assessment theme.

The ***Technical qualifications guides on marking and moderation*** are essential guidance documents and are available on the City & Guilds website. These provide further information on preparing for assessment, evidence gathering, standardisation, marking and moderation, and must be referred to when planning and carrying out assessment.

### **Video and photograph evidence in T Level Technical qualifications**

The assessment materials for each synoptic assignment identify the minimum candidate and assessor evidence requirements to support marking and moderation. Where ephemeral evidence (e.g. areas of candidate performance that may be hard to capture with photographs and assessor notes alone) plays a significant part of the synoptic practical assessment. If this is the case, City & Guilds will prescribe the type/capture where the use of video is necessary for practical assessment components (e.g. specifying exactly which elements of the practical must be videoed, or photographed), and any technical specifications for these forms of evidence e.g. length of videos, maximum file sizes etc will also be supplied. Photographic and video evidence will be submitted along with the written candidate evidence and tutor evidence (practical observation forms) as described in the additional evidence section of the task.

Video evidence must meet these minimum requirements, to be considered by moderators:

- As per the guidance in section 2.3.2 of *The Marking and Moderation Guide for Centres*, tutors must ensure that this evidence can be easily matched to the correct candidate and task, is clearly shot, well-lit and shows the areas of particular interest in sufficient detail and clarity for assessment (i.e. filmed at appropriate points in production, showing accuracy of measurements where appropriate).
- The qualitative written evidence provided by tutors must
  - clearly identify the parts of the video that are being referred to, when used as supporting evidence. Using a timecode for this is recommended
  - include their judgement on the performance being demonstrated.
- Section 6.5 of the *Centre Manual* also contains general information about the requirements for video evidence submission, however for Technical Qualifications, videos must be no longer, than 5 minutes long.



Please note that where video evidence is unclear, or does not meet these minimum requirements, moderators will disregard it.

## Minimum evidence requirements for marking and moderation

The sections in the assignment:

- ***What you must produce for marking***, and
- ***Additional evidence of your performance that must be captured for marking***

These list the minimum requirements of evidence to be submitted for marking and the moderation sample.

Evidence produced during assessment above and beyond this may be submitted, as long as it provides useful information for marking and moderation and has been produced under appropriate conditions.

While technological methods which support the capturing or creating of evidence can be helpful, e.g. pin board style websites for creating mood boards, the final evidence must be converted to a suitable format for marking and moderation which cannot be lost/ deleted or amended after the end of the assessment period (e.g. screen prints, pdf files). Considerations around tracking authenticity and potential loss of material hosted on such platforms during assessment is the centre's responsibility.

*Note: Combining candidates' individual pieces of evidence into single files or zip files may make evidence management during internal marking more efficient and will greatly simplify the uploading of the moderation sample.*

Where the minimum requirements have not been submitted for the moderation sample by the final moderation deadline, or the quality of evidence is insufficient to make a judgement, the moderation, and therefore any subsequent adjustment, will be based on the evidence that *has* been submitted. **Where this is insufficient to provide a mark on moderation, a mark of zero may be given.**

## Preparation of candidates

Candidates should be aware of which aspects of their performance will give them good marks in assessment. This is best carried out through routinely pointing out good or poor performance during the learning period, and through formative assessment.

During the learning programme, direct tutor instruction in how to approach tasks through modelling, support, guidance and feedback are critical. However, gradual removal of this support is necessary in preparation for summative assessment. This supported approach is not valid for summative assessment.

The purpose of summative assessment is to confirm the standard the candidate has reached as a result of participating in the learning process. Candidates should be encouraged to do the best they can and be made aware of the difference between these summative assessments and any formative assessments they have been subject to. Candidates may not have access to the full marking grids. Refer to the ***T Level Technical qualifications – teaching, learning and assessment*** centre guidance document, available on the City & Guilds website for further information on preparing candidates for Technical qualification assessment.

## **Guidance on assessment conditions**

The assessment conditions that are in place for this synoptic assignment are to:

- ensure the rigour of the assessment process
- provide fairness for candidates
- give confidence in the outcome.

They can be thought of as the rules that ensure that all candidates who take an assessment are being treated fairly, equally and in a manner that ensures their result reflects their true ability.

The conditions outlined below relate to this synoptic assignment. These do not affect any formative assessment work that takes place, although it is advised that candidates are prepared for the conditions they will need to work under during summative assessment.

The evidence for the tasks that make up this synoptic assignment must be completed under the specified conditions. This is to ensure authenticity and prevent malpractice as well as to assess and record candidate performance for assessment in the practical tasks. Any aspect that may be undertaken in unsupervised conditions is specified. It is the centre's responsibility to ensure that local administration and oversight gives the tutor sufficient confidence to be able to confirm the authenticity of the candidate's work.

## **Security and authentication of candidate work**

Candidate evidence must be kept secure to prevent unsupervised access by the candidate or others. Where evidence is produced over a number of sessions, the tutor must ensure learners and others cannot access the evidence without supervision. This might include storing written work or artefacts in locked cupboards and collecting memory sticks of evidence produced electronically at the end of each session.

Candidates are required to sign declarations of authenticity, as is the tutor. The relevant form is included in this assignment pack and must be signed after the production of all evidence.

**Where the candidate or tutor is unable to or does not confirm authenticity through signing the declaration form, the work will not be accepted at moderation and a mark of zero will be given. If any question of authenticity arises e.g. at moderation, the centre may be contacted for justification of authentication.**

## **Accessibility and fairness**

Where a candidate has special requirements, tutors should refer to the **Access arrangements and reasonable adjustments** section of the City & Guilds website.

Tutors can support access where necessary by providing clarification to any candidate on the requirements or timings of any aspect of this synoptic assignment. Tutors should not provide more guidance than the candidate needs as this may impact on the candidate's grade, see the guidance and feedback section below.

All candidates must be provided within an environment, time frame and resources that allows them reasonable access to the full range of marks available.

Where candidates have worked in groups to complete one or more tasks for this synoptic assessment, the tutor must ensure that no candidate is disadvantaged as a result of the performance of any other team member. If a team member is distracting or preventing another team member from fully demonstrating their skills or knowledge, the tutor must intervene.

## **Guidance and feedback**

To support centre file management, tutors may specify a suitable file format and referencing format for evidence (unless otherwise specified e.g. if file naming is an assessment point for the assignment). Guidance must only support access to the assignment brief and must not provide feedback for improvement. The level and frequency of clarification & guidance must be

- recorded fully on the candidate record form (CRF)
- taken into account along with the candidate's final evidence during marking
- made available for moderation.

Tutors must not provide feedback on the quality of the performance or how the quality of evidence can be improved. This would be classed as malpractice. However, this does not apply if the tutor asks questions as part of the assessment process. Such requirements will be specifically stated within task centre guidance.

Tutors should however provide general reminders to candidates throughout the assessment period to check their work thoroughly before submitting it, and to be sure that they are happy with their final evidence as it may not be worked on further after submission.

Candidates can rework any evidence that has been produced for this synoptic assignment during the time allowed. However, this must be as a result of their own review and identification of weaknesses and not as a result of tutor feedback. Once the evidence has been submitted for assessment, no further amendments to evidence can be made.

Tutors should check and be aware of the candidates' plans and designs to ensure management of time and resources is appropriate, and so any allowed intervention can take place at an appropriate time.

Tutors should ensure that candidates' plans for completion of the tasks distribute the time available appropriately and may guide candidates on where they should be up to at any point in a general way. Any excessive time taken for any task should be recorded and should be taken into account during marking, if appropriate.

It is up to the marker to decide if the guidance the candidate has required suggests they are lacking in any performance outcome, the severity of the issue, and how to award marks on the basis of this full range of evidence. The marker must record where and how guidance has had an impact on the marks given, so this is available should queries arise at moderation or appeal.

## **What is, and is not, an appropriate level of guidance**

- A tutor should intervene with caution if a candidate has taken a course of action that will result in them not being able to submit the full range of evidence for assessment. However, this should only take place once the tutor has prompted the candidate to check that they have covered all the requirements. Where the tutor has to be explicit as to what the issue is, this is likely to demonstrate a lack of understanding on the part of the candidate rather than a simple error, and full details should be recorded on the candidate record form (CRF)
- The tutor should not provide guidance if the candidate is thought to be able to correct the issue without it, and a prompt would suffice. In other words, only the minimum support the candidate actually needs should be given, since the more tutor guidance provided, the less of the candidate's own performance is being demonstrated and therefore the larger the impact on the marks awarded

- A tutor must not provide guidance that the candidate's work is not at the required standard or how to improve their work. In this way, candidates are given the chance to identify and correct any errors on their own, providing valid evidence of knowledge and skills that will be credited during marking
- The tutor must not produce any templates, pro-formas, work logs etc unless instructed to in the assignment guidance. Where instructed to do so, these materials must be produced as specified and contain no additional guidance. Templates provided, as part of the assignment should be used as provided, and not adapted.

All specific prompts and details of the nature of any further guidance must be recorded on the relevant form and reviewed during marking and moderation.

### **Guidance on marking**

Please refer to the ***T Level Technical qualifications – marking, and - moderation*** centre guidance documents for further information on gathering evidence suitable for marking and moderation, and on using the marking grid and forms.

The CRF is used to record:

- Details of any guidance or the level of prompting the candidate has received during the assessment period
- Rough notes bringing together relevant evidence from across tasks during marking.
- Summary justifications when holistically coming to an overall judgement of the mark for each performance objective and overall.

The practical observation form is used to record:

- Descriptive information and evidence of candidate performance during an observation.

## Marking grid guidance

### Carrying out marking using assessment themes

The process of marking each assessment theme is iterative and should follow the process below which will become more spontaneous over time as the descriptors become familiar. It is recommended to refer back to these frequently however, so the standard does not unintentionally drift over the marking period.

The indicative content gives an indication of the expected content parameters the responses are likely to cover, and which aspects of the evidence are relevant. It is not exhaustive, and an acceptable answer may concentrate more on depth rather than fully cover the range indicated or deviate into relevant topics not listed.

The specific task evidence listed within the assessor guide and marking grid must be used to make a judgement on performance in relation to the specific assessment theme.

The assessment tasks guide the production of valid evidence under appropriate conditions for assessment. Candidate evidence from a range of tasks may contribute to the marking of a single assessment theme, or from a single task to more than one assessment theme. In this case, different aspects of the evidence are being considered for each theme and need to be judged against the marking descriptors specified in the assessment themes independently of each other.

In some cases, the quality indicators looked for in the judgement may naturally be more strongly evidenced in one piece of evidence than another. For instance, more formulaic/prescriptive forms of evidence may not be able to generate evidence of higher levels of performance, so this evidence would need to be looked for in the other forms of evidence. This means that where a range of evidence is to be assessed, it should be treated as a single package of evidence for the purposes of marking even if generated through different tasks.

### Timing of marking

As some assessment themes require the triangulation of a number of pieces of evidence, marking cannot take place until after all of these are available. This does not, however, mean that all marking needs to take place after all candidates have completed the whole assessment.

Also, it is possible to begin recording the notes that will justify the marking for some assessment themes as evidence is produced, with the final mark only being decided once the complete array of evidence is available. This is particularly the case if later evidence is more confirmatory, and the earlier evidence is sufficiently informative for the qualities being assessed to make this a useful exercise.

Through planning, it should be possible to identify any evidence that can start being reviewed earlier, and the assessment themes which could be scheduled for earlier completion of marking e.g. while observation evidence is fresh in the mind should this be helpful. Care must of course be taken to ensure any evidence required by candidates to progress with another task are available for that task to take place. In addition, it is recommended that a sense check across marking for each assessment theme, and across assessors, is carried out at the end to ensure marking has not drifted during the period. This may take the form of comparing candidate work to check that the ranking of quality of evidence matches the ranking of marks – where there are discrepancies marking should be checked for accuracy.

## Process for each assessment theme:

- Select the range of evidence relevant for making the judgement – this is indicated in the mark scheme for each assessment theme.
- Scan/read the candidate evidence, evidence captured by the assessor and the indicative content & band descriptors in the mark scheme.
- Make an initial assessment of the required evidence as a whole, considering each band in turn to make a balanced judgement of the best band to use it as a starting point.
- Read the evidence and review it against the band descriptor in more detail,

deciding if the response is securely sitting within the band; i.e. all quality characteristics described by the band descriptor are seen, and strongly meets the level of performance described by the descriptor holistically (i.e. across the range of relevant evidence).

- Check the descriptor for the level above
- If the evidence clearly shows some of the characteristics of the higher band, select a suitable mark at the bottom of that band
- If *not* showing characteristics of the higher band revert to the original band, select a mark at the higher end of that mark range

If the response is not securely in the band, but *is partially* showing the characteristics of the band,

- check the descriptor of the level below.
- decide on a suitable mark either at the bottom of the original band as some characteristics shown, or top of the lower band if it better describes the quality of the characteristics being shown.

If the response is largely meeting the band, with only a few concerns, and is not showing characteristics aligning with the higher or lower bands, the appropriate mark is likely to be in the middle range.

If there is no alignment with the descriptor, reassess the starting band, and begin again.

- Based on the level of alignment with the descriptor, confirm the final mark within the band, bearing in mind that the available marks form an *evenly distributed scale*:
  - If the quality of response *fully* aligns with the performance described by the descriptor – assign a high mark within the band
  - If the quality of the response *partially* aligns with the performance described by the descriptor – assign a low to medium mark within the band
  - Consider the quality compared to a range of similar responses (e.g. relevant annotated training material exemplars, responses reviewed during standardisation, and through experience) choose a mark on the point on the scale that would give an appropriate ranking for the assessed piece of evidence in relation to this information and in comparison, with that of the rest of the cohort for that assessment theme.

## Marking grid

There is a marking grid for each assessment theme that must be assessed as part of this occupational specialism assessment.

### Assessment theme - Health and Safety

<p><b>Note: where there is insufficient evidence to award a mark, a zero mark may be given</b></p>	<p><b>Band 1 descriptor</b></p>	<p><b>Band 2 descriptor</b></p>	<p><b>Band 3 descriptor</b></p>	<p><b>Total marks per assessment theme</b></p>
<p><b>Indicative content</b></p>	<p><b>Typical knowledge, understanding and skills:</b></p> <p>Identify main hazards which include major danger of death or major injury hazards. It is expected that candidates are able to analyse the risk and produce appropriate mitigation against these hazards for the planned task. Demonstrate knowledge and understanding of minor injury or delay hazards and provide appropriate mitigation for such risks.</p> <p>Correctly prepare tools, PPE and materials lists for the proposed installation. Maintain a tidy work area throughout the task.</p> <p>Correct PPE must be worn at all times and as designated in their risk assessment. (If unsafe working occurs, the assessment is to be stopped immediately).</p> <p>Demonstrate the knowledge and understanding of safe isolation through carrying out correct safe electrical isolation procedure in a logical order that is specified below. (Failure to complete safe isolation as specified below that leads to an unsafe situation the assessment will be stopped immediately).</p>			

	<p><b>Safe isolation</b></p> <ul style="list-style-type: none"> <li>• Obtain permission to start work</li> <li>• Prove that the approved voltage indicator is functioning correctly</li> <li>• Identify the source(s) of supply using an approved voltage indicator</li> <li>• Isolate the supply, lock off and retain the key</li> <li>• Prove the system/equipment is DEAD (L-E, N-E &amp; L-N) using an approved voltage indicator</li> <li>• Prove that the approved voltage indicator is functioning correctly</li> <li>• Put up warning signs to tell other people that the electrical installation has been isolated</li> <li>• Once the system/equipment is proved DEAD, work can begin.</li> </ul>			
<b>Marks per band</b>	<b>1-4</b>	<b>5-8</b>	<b>9-12</b>	<b>12</b>
	<p>Risk assessment is complete and covers the key risk factors. Risk mitigation methods are limited.</p> <p>Likelihood against probability has been attempted but not for all hazards.</p> <p>Health and safety is followed during preparation and throughout tasks so that all work is completed safely but when working some low-risk hazards were missed.</p>	<p>Risk assessment is complete and covers a good range of risk factors.</p> <p>Risk mitigation methods have been identified for some of the potential risks, but not all. Consideration is given to potential for harm and probability factors.</p> <p>Health and safety is followed during preparation and throughout tasks and all work completed safely.</p>	<p>Risk assessment is detailed and clearly identifies all of the associated risk factors.</p> <p>Risk mitigation methods are detailed and have been clearly identified for all potential risks. Potential for harm and probability factors have been identified throughout.</p> <p>Health and safety is followed during preparation and throughout tasks and all work completed safely. Risks and hazards that occur during the tasks are correctly mitigated against as they arise.</p>	



## **Guidance for markers**

Evidence from Task 2, Task 3 and Task 4 must be used to assess performance against this assessment theme.

### **Task 2**

Risk assessment

### **Task 3**

Assessor observation:

- Installation of components and system
- Safe isolation
- Pressure testing

### **Task 4**

Assessor observation:

- Fault diagnosis
- Decommissioning
- Safe isolation
- Rectification of the fault

## Assessment theme – Design and Planning

<p><b>Note: where there is insufficient evidence to award a mark, a zero mark may be given</b></p>	<p><b>Band 1 descriptor</b></p>	<p><b>Band 2 descriptor</b></p>	<p><b>Band 3 descriptor</b></p>	<p><b>Total marks per sub assessment themes</b></p>	<p><b>Total marks for assessment theme</b></p>
<p><b>Indicative document</b></p>	<p><b>Typical knowledge, understanding and skills:</b></p> <p>Produce accurate heat load calculation for a given cold storage specification. It is expected that candidates consider all possible heat loads, and calculations are clearly presented.</p> <p>Provide a detailed method statement of how the task will be carried out in a safe and logical manner with reasoning to support the methods given. It is expected that candidates have made choices in response to the assignment brief and tasks and this is justified within their reasoning. Consideration given to but not limited to the use of nitrogen, protecting pipework and other components, pressure testing, evacuation procedures, services, use of insulation and tightness testing pressures.</p> <p>Take measurements from an allocated space/work area and position components for optimal performance and use the information gathered to complete a scaled drawing of the proposed installation. For optimal performance certain components such as the solenoid valve and sight glass should be located close to the expansion valve inlet. The temperature sensor should be placed in the return air flow to the evaporator.</p> <p>Correct selection of components and tools, including pipe-bending machines, soldering equipment, and small hand tools such as wire strippers for the electrical aspects of the assignment. When selecting materials, consideration must be given to the type, size and quantity to complete the task in a timely manner and to ensure the highest quality of finish which shows no evidence of damage to systems including pipework or aesthetics.</p>				

<b>Marks per band</b>	1-2	3-4	5-6	<b>6</b>	<b>24</b>
<b>Calculations</b>	<p>Demonstrates some knowledge and understanding of considerations that impact design.</p> <p>Some calculations are accurate but there is minimal working shown to evidence that all factors have been considered. This results in the overall calculation not being accurate and outside of the expected tolerance of +/- 6.25%. There are minimal units specified and presentation of work is not clear.</p>	<p>Demonstrated good knowledge and understanding of considerations that impact design.</p> <p>Calculations are accurate but there are gaps in workings that does not clearly show that all factors have been considered. The overall calculation is within tolerance of +/- 6.25%. Some units are not specified. Presentation of work is mostly clear.</p>	<p>Demonstrated comprehensive knowledge and understanding of considerations that impact design.</p> <p>All calculations are accurate with all factors considered and working out shown in detail. All units are nominated, and calculations are presented to a uniformed number of decimal places. Presentation of work is fully clear.</p>		
<b>Marks per band</b>	1-3	4-6	5-9	<b>9</b>	
<b>Documents</b>	<p>Documents are brief but correct in process but with minor inaccuracies. Content is presented logically and in sequence. No clear reasoning is provided that makes links to the assignment brief that justifies choices made, which demonstrates limited knowledge and understanding in some topic areas.</p>	<p>Documents are clear, and the correct process is set out in a logical sequence. Some reasoning is provided, and minimal links have been made to the brief and tasks to justify choices made which demonstrates good knowledge and understanding of most topic areas.</p>	<p>Documents are thorough and comprehensive. Processes are set out in a logical order. There is detail on how to perform tasks with clear reasoning that links to the assignment brief and tasks to justify choices made demonstrating an in-depth knowledge and understanding of all topic areas.</p>		

	Equipment and materials selected are basic and lack detail, resulting in a delay to complete the task in an appropriate time and an installation/service that is complete but untidy.	Equipment and materials selected are appropriate to ensure the task can be completed in a timely manner. The selection of equipment also demonstrates that both the installation/service and the quality of finish has been considered. This has resulted in a completed and tidy installation/service.	Equipment and materials selected are comprehensive and detailed that result in tasks being completed to a high standard that is demonstrated through a timely completion and an installation/service that is tidy and of a high-quality finish.		
<b>Drawings and diagrams</b>	1-3	4-6	7-9	<b>9</b>	
	Installation drawing is complete with only minor inaccuracies in pipe layout.  Position of components is correct without consideration of aesthetics.	Installation drawing is complete with only minor inaccuracies in pipe layout.  Position of components is correct with some consideration of aesthetics.	Installation drawing is complete and accurate.  Position of components is correct with consideration of aesthetics.		

**Guidance for markers**

Evidence from Task 1 and Task 2 must be used to assess performance against the assessment theme.

**Task 1**

Calculations

**Task 2**

Method statement

Material list

Scaled drawing

## Assessment theme – Systems and components

Note: where there is insufficient evidence to award a mark, a zero mark may be given	Band 1 descriptor	Band 2 descriptor	Band 3 descriptor	Total marks for assessment theme
<b>Indicative content</b>	<p><b>Typical knowledge, understanding and skills:</b></p> <p>Select components for installation and complete the activity to industry standard including the following of all manufacturer’s guidance as appropriate.</p> <p>The installation should pay attention to safe isolation procedure and correct wiring of the refrigeration system. All electrical wiring and terminations should be in accordance with BS7671 18<sup>th</sup> Edition IEE Regulations. Correct use of tools, including pipe-bending machines and brazing equipment, along with small hand tools such as wire strippers for the electrical aspects of the task.</p> <p>Good use of recycling considerations and ensure that any straight lengths of pipe are removed and saved for possible reuse and all non-reusable bends and fitting are disposed of in correct manner.</p>			
<b>Marks per band</b>	1-5	6-10	11-15	<b>15</b>
<b>Systems and components</b>	<p>Marking out has been completed, methods used lacks efficiency resulting in some inaccuracies.</p> <p>Installation does not always follow logical sequencing, which</p>	<p>Marking out is mostly accurate and method used is correct, resulting in only minor inaccuracies.</p> <p>Installation follows a logical process most of the time in line</p>	<p>Marking out is accurate and uses correct method.</p> <p>Installation follows logical sequencing throughout the</p>	

	<p>impacts on timely completion of task.</p> <p>Some tolerances are met or within 2mm – 5mm.</p> <p>Pipework skills results in excessive off cuts/wasted materials.</p> <p>Use of tools is basic, and requires more than one attempt, resulting in pipework installations that may have excessive solder runs outside of joints or scorch/burn marks on wall surfaces or unit case work.</p> <p>Maintenance of systems and components does not always follow a logical process and tasks are completed with support and reassurance from the assessor on more than one occasion.</p>	<p>with the method statement, which results in a timely completion of the task.</p> <p>Most tolerances are met or within 2mm-5mm.</p> <p>Pipework skills results in some off cuts/wasted materials.</p> <p>Use of tools is good and most tasks are completed on the first attempt. Pipework installations are of a good standard but there may be some damage to the aesthetics.</p> <p>Maintenance of systems and components follows a logical process most of the time but sometimes takes more than one attempt to complete.</p>	<p>tasks in line with the method statement, which results in a timely completion of the task.</p> <p>All tolerances are met and within 2mm.</p> <p>Pipework skills results in no off cuts/wasted materials.</p> <p>Use of tools is excellent and completed on first attempt, resulting in a high-quality finish. Pipework installations are excellent with either limited or no damage to aesthetics.</p> <p>Maintenance of systems and components follows a logical process and tasks are completed.</p>	
--	--	---	---	--

### **Guidance for markers**

Evidence from Task 3 and Task 4 must be used to assess performance against the assessment theme.

### **Task 3**

Completed installation

Assessor observation:

- Measure and marking out
- Installation of components and system
- Pressure testing

### **Task 4**

Assessor observation:

- Fault diagnosis
- Decommissioning
- Rectification of the fault



## Assessment theme – Reports and information

<p><b>Note: where there is insufficient evidence to award a mark, a zero mark may be given</b></p>	<p><b>Band 1 descriptor</b></p>	<p><b>Band 2 descriptor</b></p>	<p><b>Band 3 descriptor</b></p>	<p><b>Total marks for assessment theme</b></p>
<p><b>Indicative content</b></p>	<p><b>Typical knowledge, understanding and skills:</b></p> <p>Produce a written report detailing the maintenance activity – which should include the reason for the maintenance work and the selected method of repair.</p> <p>Paperwork must include F-Gas log sheets and waste transfer notes and must be completed accurately and in full for both the installation and service and maintenance.</p> <p>Complete and detailed reports/checklists for the following activities:</p> <ul style="list-style-type: none"> <li>• Commissioning – Correct temperatures, pressures, airflow, running current, control set points, pipework insulation and condensate pumps and drains checked and operating, refrigerant quantities and type, handover to client. Complete commissioning checklist with recommendations for improvements to the design or layout to improve performance, efficiency, or aesthetics.</li> <li>• Maintenance report – Refrigeration quantities removed and replaced, reasons for repair, method of repair, materials used, tightness and pressure testing, evacuation and charging and final operation measurements recorded.</li> </ul> <p>Information and terminology should be accurate throughout and presented clearly.</p>			

<b>Marks per band</b>	1-3	4-6	7-9	<b>9</b>
<b>Reporting and information</b>	<p>All legislative paperwork was completed with gaps in the information provided. Guidance was needed to complete some of the information.</p> <p>Reports/checklists are partially completed/brief in content with some incorrect terminology. No reasoning or justification to the method or choices made.</p>	<p>All legislative paperwork was completed minor inaccuracies.</p> <p>Reports/checklists are completed in a clear format with only minor details missing. Content and terminology are mostly accurate. Some justification and reasoning for the work required is explained.</p>	<p>All legislative paperwork was completed in full, accurately.</p> <p>Reports/checklists are detailed and accurate with correct terminology throughout. Clear justification and reasoning for works required.</p>	

### **Guidance for markers**

Evidence from Task 3 and Task 4 must be used to assess performance against the assessment theme.

### **Task 3**

Commissioning checklists

Test certificates

### **Task 4**

Service and maintenance report

Legislative paperwork i.e. F-Gas logs

## Assessment theme – Inspecting and testing of systems and components

Note: where there is insufficient evidence to award a mark, a zero mark may be given	Band 1 descriptor	Band 2 descriptor	Band 3 descriptor	Total marks for assessment theme
<b>Indicative content</b>	<p><b>Typical knowledge, understanding and skills:</b></p> <p>Set up and use high pressure nitrogen cylinders and regulators to perform pressure testing of systems.</p> <p>Select appropriate leak testing fluids.</p> <p>Demonstrate the correct set up and weigh in the correct amount of refrigerant and carry out appropriate tests and readings to ensure the system is correctly charged and working at maximum efficiency.</p> <p>There should be minimal or no loss of refrigerant to the atmosphere throughout the process.</p>			
<b>Marks per band</b>	1-4	5-8	9-12	<b>12</b>
<b>Inspecting and testing of systems and components</b>	<p>Pressure and leak tests were completed but needed guidance and reassurance from assessor on more than one occasion.</p> <p>Charging was completed safely but not always logically, with some loss of refrigerant to the atmosphere.</p>	<p>Pressure and leak tests were completed but for some tests more than one attempt to was needed to complete testing.</p> <p>Charging was completed safely with minimal loss of refrigerant to the atmosphere.</p>	<p>Pressure and leak tests were completed first time with no guidance.</p> <p>Charging was completed with no loss of refrigerant to the atmosphere.</p>	

	<p>Commissioning checks are inaccurate in sequence, resulting in issues that the candidate can rectify by having to perform the commissioning checks again.</p> <p>Candidate refers to manufactures instructions at no stage of the task.</p>	<p>Commissioning checks are mostly accurate in sequence with some checks needing to be repeated.</p> <p>Candidate refers to manufactures instructions at some stages of the task.</p>	<p>Commissioning checks are accurate in sequence and completed at the first attempt.</p> <p>Candidate refers to manufactures instructions throughout the task.</p>	
--	---	---	--	--

### Guidance for markers

Evidence from Task 3 and Task 4 must be used to assess performance against this assessment theme.

#### Task 3

Assessor observation:

- Installation of systems components

#### Task 4

Assessor observation:

- Fault rectification

## Assessment theme – Handover & Communication

Note: where there is insufficient evidence to award a mark, a zero mark may be given	Band 1 descriptor	Band 2 descriptor	Band 3 descriptor	Total marks for assessment theme
<b>Indicative content</b>	<p><b>Typical knowledge, understanding and skills:</b></p> <p>On handover, inform and demonstrate to the customer the correct use, operation and setting of the installation including how to care for the refrigeration unit. Customers should be made aware of maintaining both internal and external airflow, not blocking any airflows and any limitations in performance such as minimum operating temperature.</p> <p>Confident in the operation and setting of the equipment and be able to use clear and informative explanations of the equipment's use.</p> <p>Detail to the customer the basic maintenance and care operations that they can perform or when to ask for professional assistance.</p>			
<b>Marks per band</b>	1-2	3-4	5-6	<b>6</b>
<b>Handover &amp; Communication</b>	<p>Interaction with customer demonstrated basic customer care skills but did not confirm customer understanding.</p> <p>The explanation of how the</p>	<p>Interaction with customer demonstrated some good customer care skills, through using appropriate language and checking the customer understood.</p> <p>How to operate and maintain</p>	<p>Interaction with customer demonstrated strong customer care skill, adapting to type of customer and through using appropriate language and checking the customer understood.</p> <p>How the system operates and</p>	

	<p>system operates was clear but there were gaps in how to maintain such a system.</p> <p>Demonstration of system provided basic functions. Some information was unclear resulting in the customer having to ask questions.</p>	<p>such systems were explained clearly most of the time which the customer could understand.</p> <p>Demonstration of system was clear and provided all functions of the system.</p>	<p>required maintenance was explained in detail which the customer could clearly understand.</p> <p>Demonstration of system was thorough and provided all functions and information. Candidate proactively checked and confirmed customer understanding.</p>	
--	---	---	--	--

**Guidance for markers**

Evidence from Task 3 and Task 4 must be used to assess performance against this assessment theme.

**Task 3**

Assessor observations

- Handover

**Task 4**

Assessor observations

- Fault diagnosis

## Assessment theme – Working with faults

Note: where there is insufficient evidence to award a mark, a zero mark may be given	Band 1 descriptor	Band 2 descriptor	Band 3 descriptor	Total marks for assessment theme
<b>Indicative content</b>	<p><b>Typical knowledge, understanding and skills:</b></p> <p>Carry out fault finding tests to ensure correct diagnosis of fault. Techniques should include speaking to the customer, systematic and logical approach to fault finding.</p> <p>Correct selection and use of multimeters and insulation resistance testers to diagnose the compressor faults.</p> <p>Demonstrate the correct set up of the recovery unit, checking the safe-fill volume of the recovery cylinder and use of scales to prevent overfilling. The process should be completed with minimal, or no loss of refrigerant to the atmosphere.</p> <p>The compressor change should be conducted with minimal or no damage to the unit casing or other components with any replacement pipework matching the original.</p>			
<b>Marks per band</b>	1-4	5-8	9-12	<b>12</b>
<b>Working with faults</b>	Fault-finding techniques were carried out but were limited and showed a basic knowledge and understanding of fault-finding techniques.	Fault-finding techniques were carried out with some success demonstrating knowledge and understanding of fault-finding techniques that was appropriate.	Fault-finding techniques were carried out systematically and logically displaying accurate knowledge and understanding of fault-finding techniques.	

	<p>Minimal reference made to manufacturer's instructions.</p> <p>Decommissioning process does not always follow correct sequence, which may impact on timely completion of task. Process was completed safely with support and guidance.</p> <p>Rectification of fault follows a logical process, and the system is operational but there is clear damage to aesthetics.</p>	<p>Reference was made to manufacturer's instructions at some points during the fault diagnosis.</p> <p>Decommissioning mostly follows a logical sequencing, resulting in timely completion of task. Process was completed safely but sometimes took several attempts to complete</p> <p>Rectification of fault follows a logical process, and the system is operational with minimal damage to aesthetics.</p>	<p>Reference was made to manufacturer's instructions throughout the fault diagnosis.</p> <p>Decommissioning follows a logical sequencing, resulting in timely and accurate completion of the task on the first attempt. Process was completed safely.</p> <p>Rectification of fault follows a logical process, and the system is operational with no damage to aesthetics.</p>	
--	--	--	--	--

### Guidance for markers

Evidence from Task 4 must be used to assess performance against this assessment theme.

### Task 4

Service and maintenance report

Assessor observation:

- Fault diagnosis
- Decommissioning
- Fault rectification



## Links to English, Maths and Digital skills

The table below indicates where each of the general math's, English and digital competencies have been integrated into the assignment tasks.

Task	Skills
Task 1	EC1, EC5, MC4, MC6, MC8
Task 2	EC2, EC3, EC4, EC5, MC10 MC1, MC2, MC3, MC4, MC7 DC1, DC2, DC5
Task 3	MC1, MC3 EC3, EC4 EC1, EC2, EC3, EC6, MC2, MC6
Task 4	EC5, MC1, MC2, MC6, EC1, EC2, EC3, EC4, EC6 EC1, EC2, EC3, EC4, EC6 DC1, DC2, DC5



Copyright in this document belongs to, and is used under licence from, the Institute for Apprenticeships and Technical Education, © 2020.

'T-LEVELS' is a registered trade mark of the Department for Education.

'T Level' is a registered trade mark of the Institute for Apprenticeships and Technical Education.

'Institute for Apprenticeships & Technical Education' and logo are registered trademarks of the Institute for Apprenticeships and Technical Education.