

**T Level Technical Qualification in  
Engineering, Manufacturing,  
Process and Control  
(8713-33)**

**Composites Manufacturing  
Technologies (333)**

**Practical Assignment  
Sample Candidate Pack**

**First teaching from September 2022  
Version 1.0**

# Contents

<b>1. Assessment</b>	<b>3</b>
<b>2. Candidate guidance</b>	<b>4</b>
<b>3. Assignment brief</b>	<b>7</b>

## **1. Assessment**

This assessment is for the Composites Manufacturing Technologies Occupational Specialism component of the Technical Qualification. This pack consists of a practical assignment brief, including drawings and diagrams as necessary, that you will need to use to complete your assessment tasks.

## 2. Candidate Guidance

### General guidance

This is a formal assessment that you will be marked and graded on. You will be marked on the quality and accuracy of the work you produce. It is therefore important that you carry your work out to the highest standard you can.

### Plagiarism

Plagiarism is the failure to acknowledge sources properly and/or the submission of another person's work as if it were your own. Plagiarism is not allowed in this assignment.

This assignment is an assessment of your abilities, so the work submitted must be all your own and carried out under the conditions stated. You will be asked to sign a declaration that you have not had any help with the assignment. Your assessor is allowed to give you some help understanding the instructions if necessary, but they will record any other guidance you need, and this will be taken into account during marking.

Where research is allowed, your assessor must be able to identify which work you have done yourself, and what you have found from other sources. It is therefore important to make sure you acknowledge sources used and clearly reference any information taken from them (e.g. providing as a minimum a list of web addresses/books/articles etc used).

### Timings and planning

You are advised to study the details of the assessment before starting.

You should check with your assessor that you have all the relevant materials, equipment and information/data sources that you need before starting the assessment.

You should take care when planning to make sure you have divided the time available between parts of the assignment tasks appropriately. Timings for tasks are provided within this pack to support with planning and time allocation.

If you have a good reason for needing more time, you will need to explain the reasons to your assessor and agree a new deadline date. Changes to dates will be at the discretion of the assessor, and they may not mark work that is handed in after the agreed deadlines.

Any requested changes to deadlines must be agreed by both your assessor and City & Guilds.

### Word counts

Typical word counts are to be used as approximates for guidance to support the production of sufficient evidence. The marking will relate to the quality of the evidence produced and not whether the word count have been met.

### Health and Safety

You must always work safely, in particular while you are carrying out practical tasks.

You must always follow any relevant Health and Safety regulations, Risk Assessments and codes of practice in line with centre requirements.

If your assessor sees you working in a way that is unsafe for yourself or others, they will highlight the issue and ask you to stop the task immediately. Your assessor will not be able to reassess you until they are sure you are ready for assessment and can work safely.

### **Presentation of work**

Presentation of work **must** be neat, legible and appropriate to the task, and evidence required for submission.

You should make sure that each piece of evidence including any forms are clearly labelled with your name and the assignment reference.

All electronic files must be given a clear file name that allows your assessor to identify it as your work.

Written work may be word-processed or handwritten unless stated otherwise.

All sketches and drawings should be neat and tidy, be appropriately proportioned or drawn to scale and be annotated.

Calculations should be set out clearly, with all working shown, as well as any assumptions made.

You should use appropriate units of measurement at all times, consistent with the requirements of the assignment.

### **Internet access**

Where internet access is allowed as part of a task (e.g. for research purposes) you will be advised that this is the case and be reminded of the importance of submitting your own work and the seriousness of plagiarism, malpractice and collusion. You will be advised that your browser history will be monitored and checked.

Where you are allowed the use of computer equipment for a task, equipment will be provided with internet capability disabled (e.g. Wi-Fi disabled, machine disconnected from network etc).

### **Instructions for this assignment**

Ensure you read all the provided assessment information issued by the assessor.

You must work independently and not share your work with any other candidates in these supervised assessment sessions.

Your work will be kept secure during any supervised breaks that are taken.

Internet access is **not** allowed, unless otherwise stated in the task.

You must complete all the tasks and present all evidence that is detailed in each task.

This assessment booklet contains the assignment brief.

The tasks have been separated into individual documents which will be handed to you at the start of each task.

### **Within each task you will find the following:**

- **Conditions of assessment:** This will tell you the duration and rules you **must** follow when completing a task.
- **Controlled conditions:** This will tell you the rules you **must** follow when completing each task e.g. You **must** not share or discuss your work with other candidates.

- **What you must produce for marking:** This describes the evidence you **must** submit when the task is completed. Be aware, failure to submit any evidence requested can adversely affect your overall mark for the assessment.
- **Additional evidence for this task:** This describes other forms of evidence that will be collected by the assessor to support the marking of your performance. This will often include but not limited to photographic and video evidence.

### Assessment themes

You will be assessed against a number of assessment themes. This assignment has a total of 90 marks. The table below shows the weighting of the marks for each of the assessment themes.

Assessment theme	Weighting %
Health and safety	13%
Planning and preparation	20%
Production	50%
Quality review and evaluation	17%

### 3. Assignment Brief

You are working as a composite materials technician in a large-scale composite fabrication facility. You have been asked to join a team of composite engineers that are setting up production processes to create small batch (100 parts per batch) production of composite components.

You have been tasked with producing an assembly to be used as a spacer block within the aerospace industry to ensure the correct spacing of wing skins in a jig during the manufacturing process.

Each component has a number of plies which are either laid up on a platen or onto a core material.

Technical drawings for the assembly have been provided by the design department which indicate the specified composite materials to be used for the construction of the spacer block assembly.

You are required to:

- create a sample spacer block assembly using specified composite materials and the vacuum bag consolidation method
- perform in-production quality checks to ensure the dimensions and make any required adjustments to conform to the specification
- quality test the finished spacer block assembly
- evaluate the processes utilised and evaluate your work
- identify and attribute faults in other manufactured assemblies to deficiencies in material selection, production or process
- record and present your findings to your supervisor at a handover meeting.

This assignment has a time allocation of **24 hours and 15 minutes**.

Figure 1 – Completed assembly view

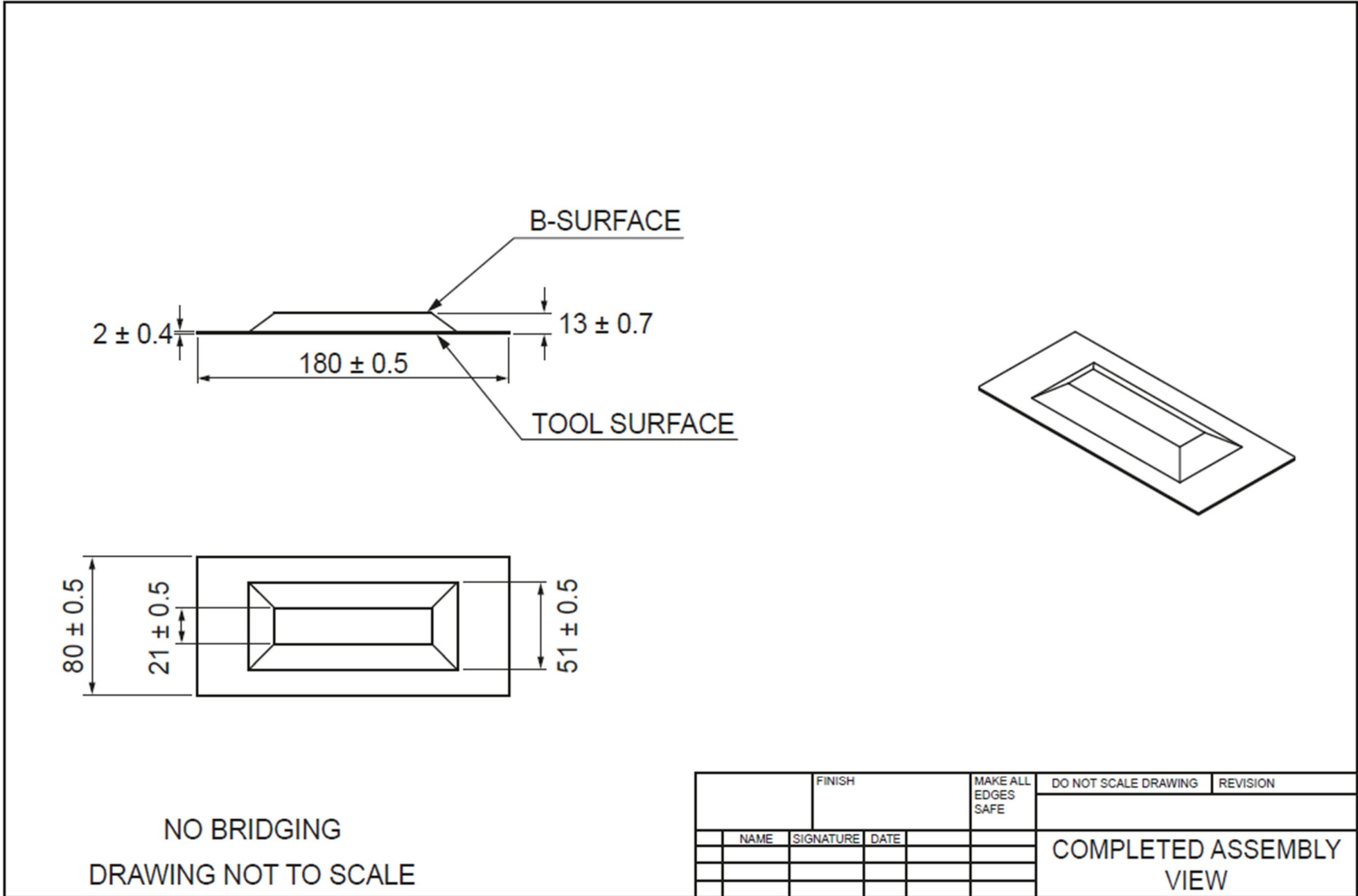



Figure 2 – Exploded assembly

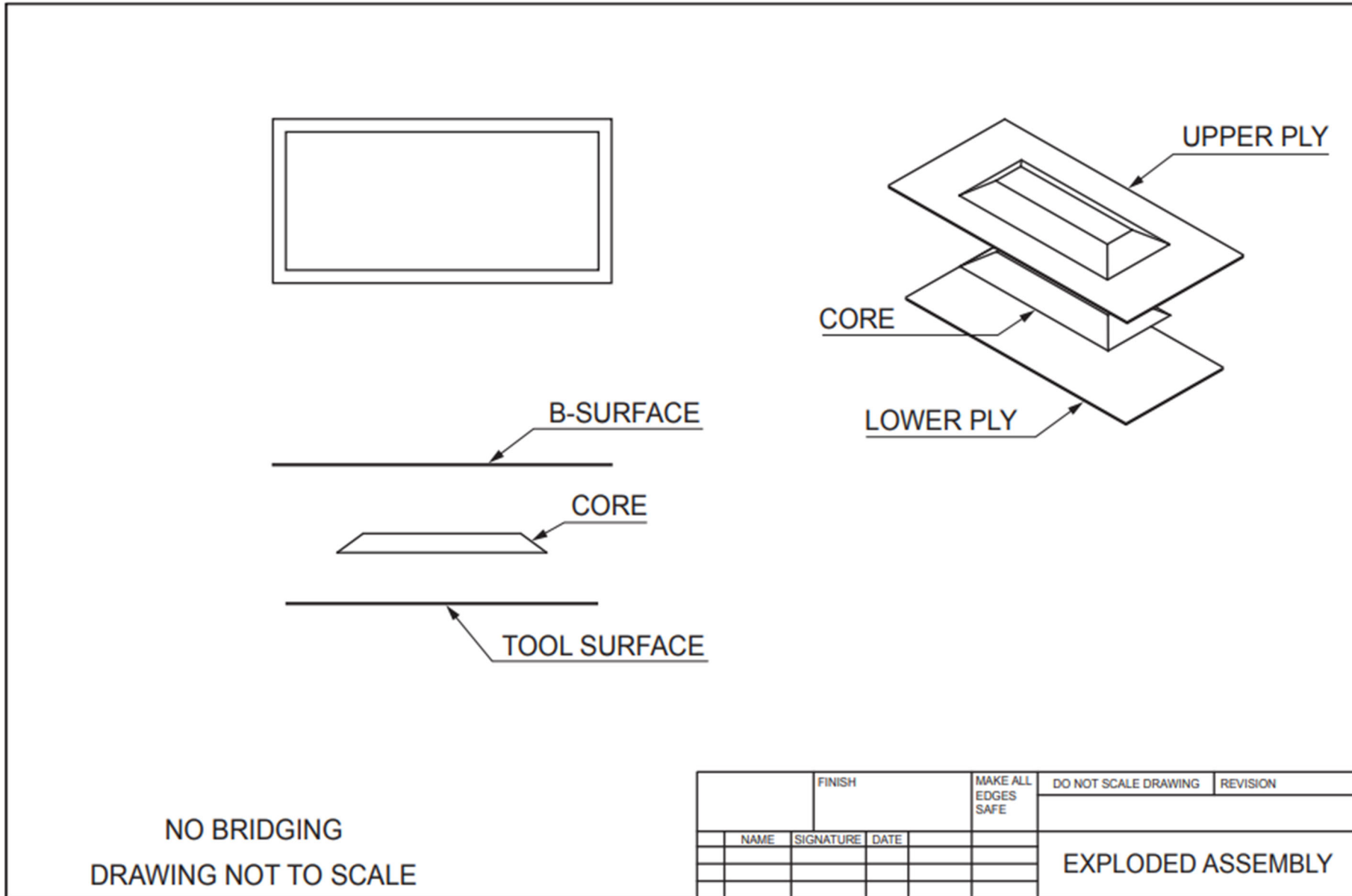

Figure 3 - Lower ply arrangement

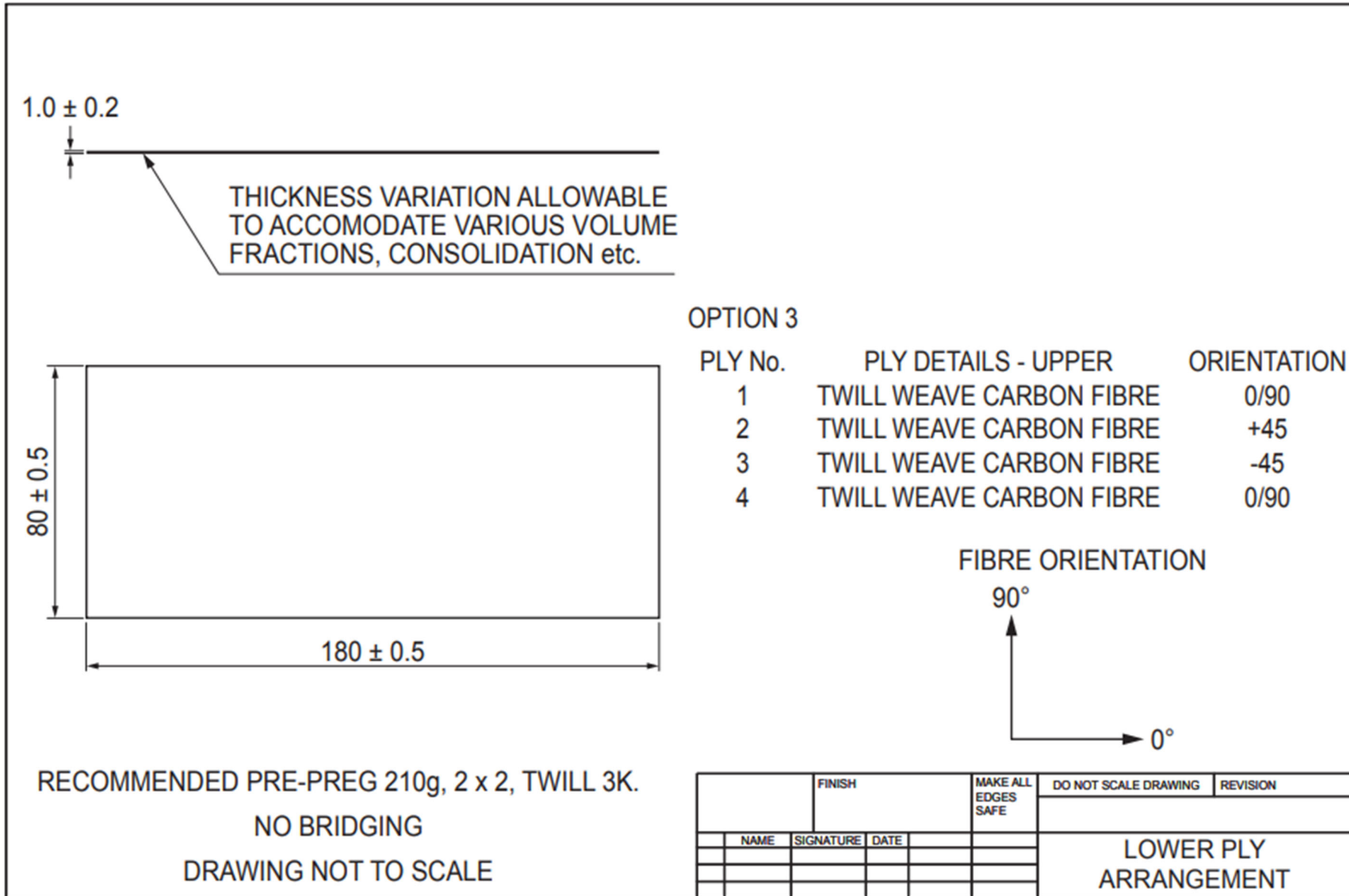
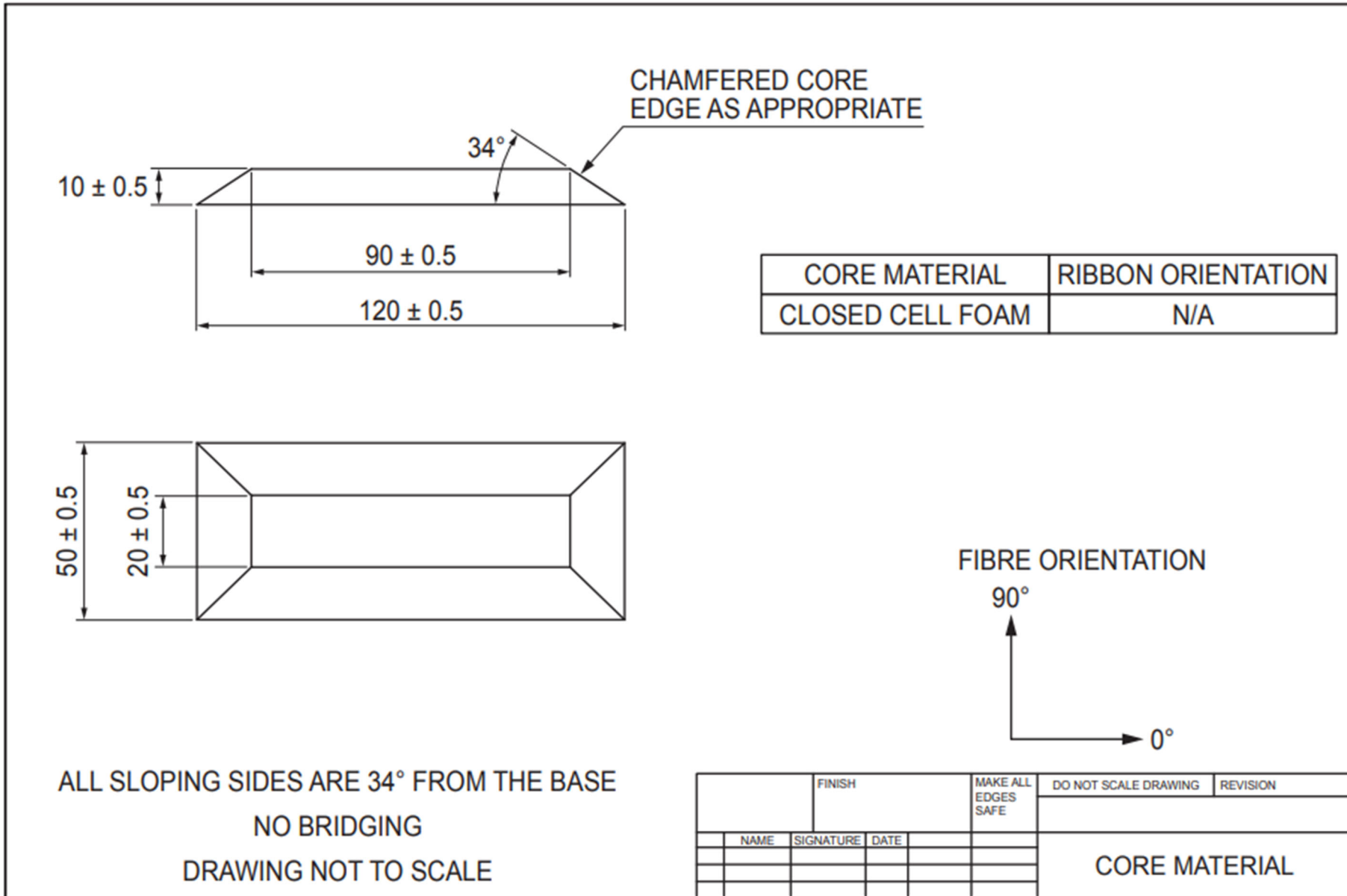
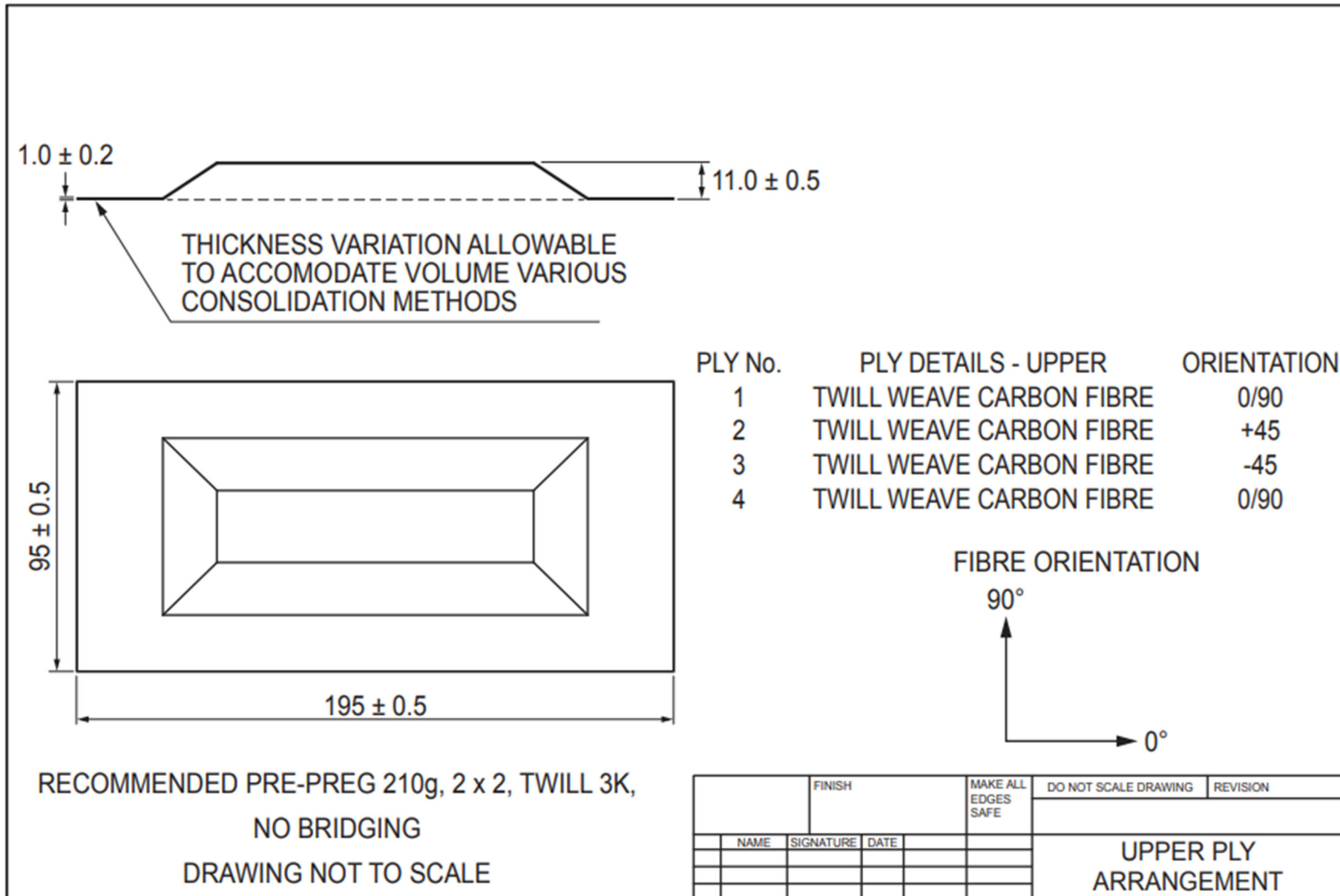

Figure 4 - Core material



**Figure 5 - Upper ply arrangement**



The T Level is a qualification approved and managed by the Institute for Apprenticeships and Technical Education.

Copyright in this document belongs to, and is used under licence from, the Institute for Apprenticeships and Technical Education, © 2021. 'T-LEVELS' is a registered trademark of the Department for Education. 'T Level' is a registered trademark of the Institute for Apprenticeships and Technical Education. 'Institute for Apprenticeships & Technical Education' and logo are registered trademarks of the Institute for Apprenticeships and Technical Education.

We make every effort to ensure that the information contained in this publication is true and correct at the time of going to press. However, City & Guilds' products and services are subject to continuous development and improvement, and the right is reserved to change products and services from time to time. City & Guilds cannot accept responsibility for any loss or damage arising from the use of information in this publication.

The City & Guilds of London Institute. All rights reserved. City & Guilds is a trademark of the City & Guilds of London Institute, a charity established to promote education and training registered in England & Wales (312832) and Scotland (SC039576). City and Guilds Group Giltspur House, 5–6 Giltspur Street London EC1A 9DE