

T Level Technical Qualification in Design and Development for Engineering and Manufacturing (8714-32)

Electrical and Electronic (322)

**Guide standard exemplification
material**

Threshold competence – Sample

First teaching from September 2022

Version 1.1

Version and date	Change detail	Section
1.1 January 2023	Formatting of Task 1 evidence requirements	Task 1

Contents

Introduction	3
Grade descriptors	4
Task 1 – Design	5
1a) <i>Design specification</i>	6
1b i) <i>Design calculations</i>	8
1b ii) <i>Justifications of design options for the sensors.....</i>	9
1b iii) <i>Circuit diagram / wiring diagram</i>	10
1b iv) <i>PCB layout.....</i>	13
1c) <i>Outcomes of the virtual modelling and circuit simulation</i>	15
1d) <i>Records of the results of testing the physical model of the circuit.....</i>	17
1e) <i>Bill of materials.....</i>	20
Task 2 – Manufacture and test.....	21
2a) <i>Risk assessment.....</i>	22
2b) <i>PCB.....</i>	24
2c) <i>Soldered prototype</i>	27
2d) <i>Testing</i>	33
Task 3 – Peer review	37
<i>Peer review feedback form</i>	38
Task 4 – Evaluation and implementation.....	40
4a) <i>Outcomes of virtual modelling.....</i>	41
4b) <i>Revision control document.....</i>	42
4c) <i>Evaluation and implementation report</i>	44

Introduction

The sample assessment materials within this document refer to the T Level Technical Qualification in Design and Development for Engineering and Manufacturing - Electrical and electronic engineering occupational specialism sample assignment. The aim of these materials is to provide centres with examples of knowledge, skills and understanding that attest to minimal threshold competence. The examples provided do not reflect all evidence from the sample assignment as the focus of this material is the quality and standards that need to be achieved rather than the volume of exemplar evidence provided. However, the examples provided are representative of all tasks in the sample assignment. The evidence presented here has been developed to reflect minimal threshold competence within each task but is not necessarily intended to reflect the work of a single candidate. It is important to note that in live assessments a candidate's performance is very likely to exhibit a spikey profile and the standard of performance will vary across tasks. Minimal threshold competence will be based on a synoptic mark across all tasks.

The materials in this Guide Standard Exemplification Material (GSEM) are separated into three sections as described below. Materials are presented against a number of tasks from the assignment.

Task

This section details the tasks that the candidate has been asked to carry out, what needs to be submitted for marking and any additional evidence required including any photographic evidence. Also referenced in this section are the assessment themes the candidates will be marked against when completing the tasks within it. In addition, candidate evidence that has been included or not been included in this GSEM has been identified within this section.

In this GSEM there is candidate evidence from:

Task 1

Task 2

Task 3

Task 4

Candidate evidence

This section includes exemplars of candidate work, photographs of the work in production (or completed) and practical observation records of the assessment completed by centre assessors. This will be exemplar evidence that was captured as part of the assessment and then internally marked by the centre assessor.

Commentary

This section includes detailed comments to demonstrate how the candidate evidence attests to the standard of minimal threshold competence by directly correlating to the grade descriptors for this occupational area. Centres can compare the evidence against the performance indicators in the marking grid descriptors within the assessor packs, to provide guidance on the standard of knowledge, skills and understanding that need to be met for minimal threshold competence.

It is important to note that the commentary section is not part of the evidence or assessment but are evaluative statements on how and why that piece of evidence meets a particular standard.

Grade descriptors

To achieve a pass (threshold competence), a candidate will typically be able to:

Demonstrate a basic use of software/ technologies to model, evaluate and produce electrical and electronic engineering diagrams and simulations that meets the requirements of the brief.

Demonstrate basic technical skills when developing models and prototypes, resulting in a model that may require some modifications.

Apply basic knowledge and understanding of testing processes, resulting in a model that has been tested against most of the design criteria.

Interpret information, plan, assess risk and follow safe working methods appropriately when applying practical skills to an acceptable standard in response to the requirements of the brief.

Apply basic knowledge and understanding of the design principles required for electrical and electronic engineering resulting in proposals and solutions that meet the minimum requirements of the brief.

Work safely showing an understanding and suitable level of awareness in the preparation and application of processes, selection and use of tools and manufacturing materials and components, resulting in tasks that are carried out with some minor errors.

Use industry and technical terminology accurately most of the time in both written and verbal contexts.

Task 1 – Design

(Assessment themes: Health and safety, Design and planning, Manufacturing, Reports)

For task 1, candidates need to produce the following pieces of evidence:

- a) design specification
- b)
 - i) design calculations, including all workings
 - ii) justifications of design options for the sensors
 - iii) circuit diagram and wiring diagram
 - iv) PCB layout
- c) outcomes of the virtual modelling of the proposed circuit design, either as screen captures or printouts
- d) records of the results of testing the physical model of the circuit
- e) bill of materials.

For Task 1, the following additional evidence may also be submitted:

- any notes produced of research undertaken including citation of sources and internet search history.

1a) Design specification

Candidate evidence

Requirements from design criteria:

- To detect if a box travelling along the conveyor is less than 200 mm high and 300 mm long within a tolerance of 10%. If it is larger than these sizes, it must be directed down chute B, otherwise it must be directed down chute A. If it exceeds EITHER of the sizes it should be directed down chute B.
- To detect when a box reaches the holding area:
 - A visual indicator (light) to indicate when a product should be directed down chute A.
 - A visual indicator (light) to indicate when a product should be directed down chute B.
 - A visual indicator (light) and audible output to indicate when a product is in the holding area.
- Methods of turning the system on and off and resetting it.

Design specification:

I have produced the following specification from the requirements listed above.

The circuitry must:

- Use infrared beams to detect the height and length of the boxes. One will be placed at a height above the conveyor belt to detect any boxes passing through under 200 mm. The size of the boxes can be calculated from the speed they are travelling at along the conveyor. The boxes can then be sent down the correct chute as outlined in the design criteria.
- Use a SPST toggle switch to turn the power to the system on and off. This will allow energy to be saved when it is not in use and make the design more sustainable.
- Use a sensor mounted above the conveyor belt to detect when a box enters the holding area. A reset button is also required once the holding area has been cleared.
- Use a microcontroller to provide the output signals to the servo motors that will control the pivot arms. This will be in the form of pulse width modulation; regular pulses every 20 ms with the width of the pulses being between 1 ms and 2 ms for minimum and maximum movement.
- Use a green LED which will light to show when a box has gone down chute A and a red LED for chute B. LEDs are cheap, robust and don't use a lot of current compared to lamps.
- Use a yellow LED and a buzzer to indicate when a product is in the holding area. The LED will provide a visual indication, whereas the buzzer will provide an audible output.
- Use single and multi-strand wires to connect the power supply and input and output devices to the circuitry. Multi-strand wires will be more resistant to damage from movement and mechanical stress which is likely in a busy production environment.
- All cables and wires must be appropriately insulated and colour-coded for electrical safety.

Commentary

The candidate has produced a brief design specification in response to the task that builds on the design criteria. The candidate has demonstrated an understanding of the design criteria by providing basic information on how they would consider developing the circuitry to meet these requirements. For example, the candidate has interpreted the need for visual and audible indicators, which they have met through using a yellow LED and a buzzer.

They have considered the specific components that would be needed in order to meet the requirements of the brief and in most cases explained briefly why these have been chosen. For example, identifying and explaining the need to use a microcontroller to provide the output signals for the servo motors. The candidate has largely structured and focused their design specification to reflect the specific design criteria points that have been given. They have briefly considered some additional factors, such as sustainability, safety, and the intended environment where the design will be used.

In order to develop their response further, the candidate could have provided further analysis of each point made and covered all of the design criteria. For example, explaining exactly how a reset function would be achieved, or more detailed justifications for the use of infra-red sensors. In addition, they could have provided greater consideration of the additional factors that would be a consideration when safely developing and embedding the application in the intended environment.

Candidate evidence

1b i) Design calculations

A tolerance of +/- 10% is required for the height (200 mm) and length (300 mm) of the boxes.

For height:

Maximum possible value = $200 + (200 \times 0.1) = 220$ mm

Minimum possible value = $200 - (200 \times 0.1) = 180$ mm

For length:

Maximum possible value = $300 + (300 \times 0.1) = 330$ mm

Minimum possible value = $300 - (300 \times 0.1) = 270$ mm

Calculations for protective resistors for LEDs:

Using Ohm's Law – $V = I \times R$, so $R = V / I$

$R = 6 \text{ V} / 25 \text{ mA}$

$R = 300 \text{ } \Omega$

Closest actual resistor value is $330 \text{ } \Omega$ so I will use this value to protect each of the three LEDs used in the system.

The servo motors will need 6 V to power them. They each draw a current of 1 A. So, output power is easily found:

$P = I \times V$

$P = 1 \text{ A} \times 6 \text{ V} = 6 \text{ W}$

From its datasheet, an 18 pin PIC microcontroller will need between 5 and 12 V for it to run correctly. I will use a 6 V supply as I can then use the same power supply as for the microcontroller. 4 x 1.5 AA batteries will provide this, or I could use a bench power supply set to 6 V.

1b ii) Justifications of design options for the sensors

Selection of Sensors



To meet the design criteria for detecting the different sized boxes I will use an infra-red beam detector. Using this type of detector for this design means that a box when travelling on the conveyor will interrupt a beam of light which is being shone across the conveyor. I have chosen this as it is a non-contact means of detection, is reliable and versatile. They are also relatively cheap to buy. For example:

<https://coolcomponents.co.uk/products/ir-break-beam-sensors-with-premium-wire-header-ends-3mm-leds?currency=GBP&variant=39363442573373>

Length and height measurements:

It must be possible to determine if the box is larger than 300mm in length. The box is assumed to travel at a constant speed along the conveyor. If the time that the box takes to pass the sensor is measured, and the speed is known, then the size can be calculated.

As with the length measurement, an exact height is not needed, it is only necessary to determine if the box is less than 200mm. A sensor placed above the conveyor bed would be able to measure this. The sensor should be placed at the maximum height (200mm) of the maximum box height to detect that the box is less than 200mm.

Holding area:

It is only necessary to detect when a box enters the holding area, so a single sensor mounted just above the conveyor bed would be sufficient. A reset button is also required once the holding area has been cleared.

1b iii) Circuit diagram / wiring diagram

Configuration of circuitry

Control System:

There are two principal methods of control that could be used to meet the brief:

- 1) Discrete Electronics, using logic gates and transistors. This is likely to get fairly complex, and if any flaws or errors are made in the design or construction of the system these could be very difficult to find and correct. However, no programming is required.
- 2) Microcontroller based system. The electronic interfacing should be relatively straightforward, with the complex details being taken care of in software.

A microcontroller-based system will be used, as the discrete electronics route is likely to become unwieldy very quickly. Further, any logical or sequencing issues are much easier to address in software than in hardware. The PICAXE/GENIE 18 will be suitable as it has 6 input pins, all of which can be used with digital IR sensors. It also has 8 output pins, which easily allows for both servo outputs, the three LEDs and the holding area buzzer. The sensors will be used with 10 k Ω pull-up resistors to improve reliability. This IC only provides a current of 20 mA, which can light up the LEDs, but is not sufficient for the servo motors. I will therefore need a driver stage such as a transistor or Darlington pair. The microcontroller requires between 5 V and 12 V as a power supply. I will use a 6 V supply as this can easily be produced using AA battery packs.

It is a requirement that indicator lights show when the two chutes are operated, and when a box enters the holding area. These will be LEDs as they are robust and only require a small amount of current to function. A warning buzzer is also needed for the holding area.

I will use an SPST power switch and a push button switch as a reset.

Pulse width modulation is needed to drive servos. Regular pulses every 20 ms (approx.) are needed, with the width of the pulse being between 1 ms and 2 ms for minimum and maximum movement. I do not need to select the exact servo motors as the brief only requires the signals for these to be provided.

Circuit Diagram

A circuit schematic based on an 18 pin PIC microcontroller has been designed and is shown below. As my circuit design software, Circuit Wizard, does not have an IR sensor option, I have represented these with SPST switches (SW2, SW3 and SW4) for the purpose of simulation later in the design process.

Q1 and Q2 are used to show the Darlington drivers needed to provide the extra current for the servo motors.

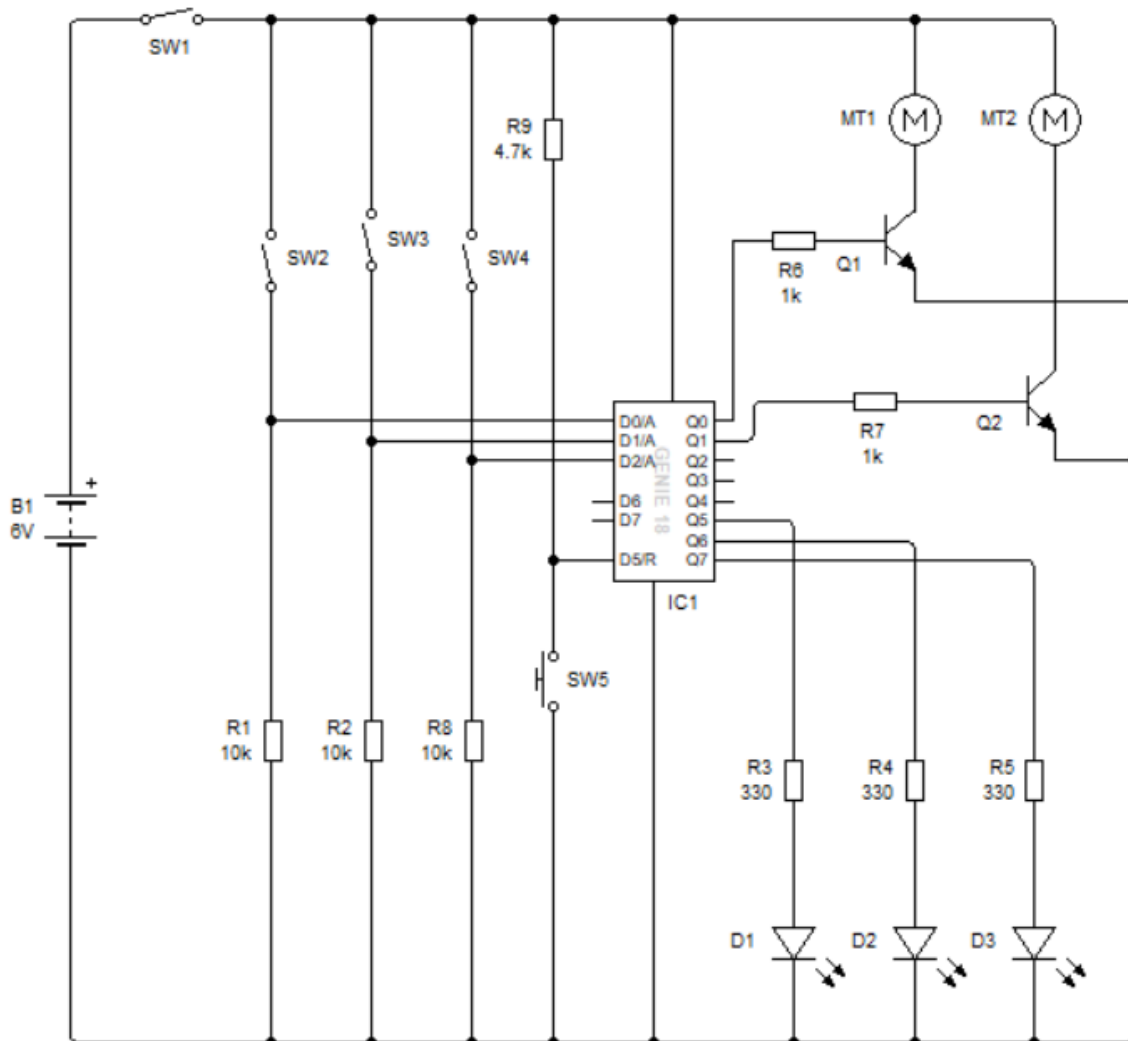

Wiring Diagram

The proposed wiring required from the main circuit board is shown below.

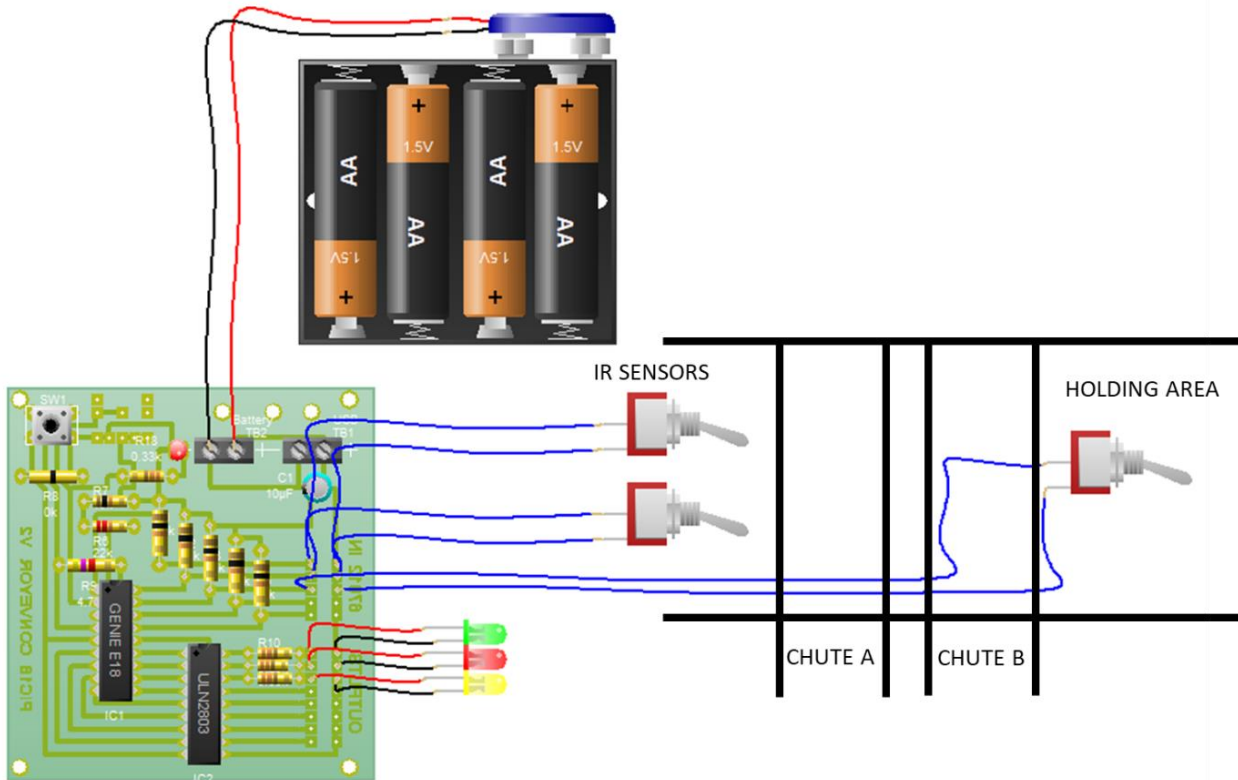

1b iv) PCB layout

A printed circuit board layout has been produced using Circuit Wizard software. Shown below are the normal, real world and artwork views.

Normal view:

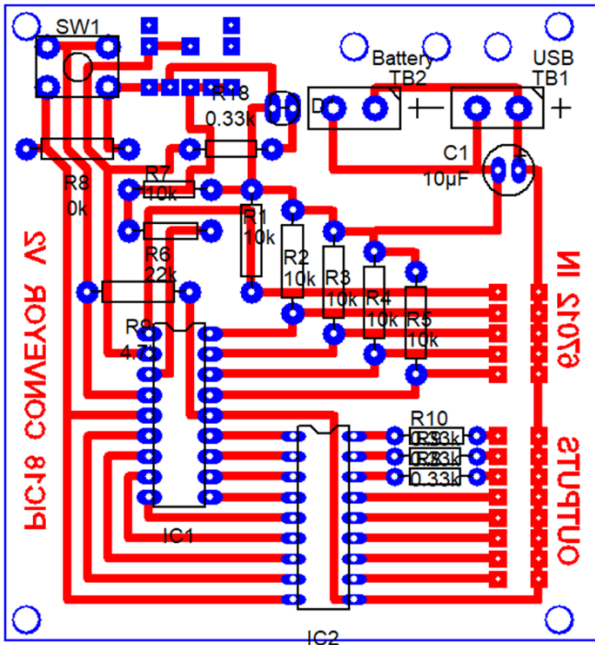

Real world view:

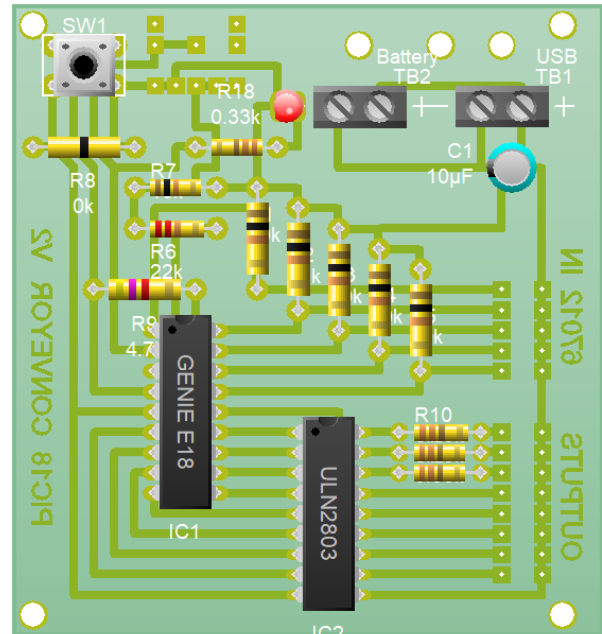

Artwork view:

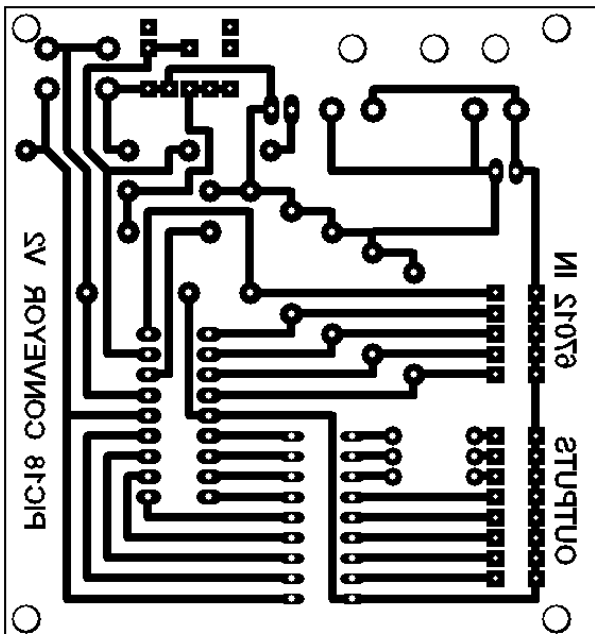

To improve the design, I made some changes from the circuit diagram when designing the PCB. I added strain holes so wiring will not break when subject to mechanical stress. I also decided to use a Darlington driver IC instead of separate Darlington pairs. This gives more flexibility if I need to add extra outputs to the circuit and reduces space on the PCB.

Commentary

The candidate has identified appropriate sensors to use in order to detect the different boxes and checking that a box is in the holding area. A brief justification has been provided for their use that links to the requirements of the design specification and criteria in the brief, for example, brief reference to the height and position of where the sensors are placed in order to support the tolerances of the boxes specified in the brief. In addition, they have considered factors related to their use, for example the need to work out the size of the box using the speed of conveyor belt and the time taken to pass it. In order to develop, the candidate could have considered the use of alternative types of sensors and compared their relative benefits and limitations.

The candidate has demonstrated basic consideration of the calculations that need to be conducted to ensure accurate application of the tolerances of the infra-red sensors, protective resistor values and overall output power of the system. Calculations identified are undertaken mostly accurately. The candidate has also considered how four 1.5 V AA batteries will be combined to provide the required 6 V power supply voltage for the circuitry. In order to develop, the candidate could have considered a wider range of calculations to support determination of the tolerances. For example, consideration of the potential effects of voltage drop across the LEDs within the resistor calculations. They could have also provided more detailed calculations to show the required output signal voltages and current from the microcontroller in order to operate the servo motors.

The candidate has described the circuitry to be used with some justifications as to why each is to be used, although this could be presented in more technical depth. They have produced a circuit schematic, wiring diagram and PCB layout which are largely accurate, meet most of the criteria and use mainly correct conventions. To develop further, they could also have produced a more technically accurate wiring diagram that shows the exact physical layout of all wiring and components. They could have produced a more detailed schematic, with further technical annotations, that meets all of the design criteria.

1c) Outcomes of the virtual modelling and circuit simulation

Candidate evidence

I used Circuit Wizard CAD software to produce a model of the proposed design for the circuit. This allowed me to check how the circuit would work by simulating the function of the schematic.

I achieved this by writing a flowchart test program (shown below) and simulating it on the schematic. As this software did not allow me to simulate IR beam sensors I used SPST switches (SW2, SW3, SW4) to simulate their function (i.e. when they produced digital 1 'on' and digital 0 'off' signals).

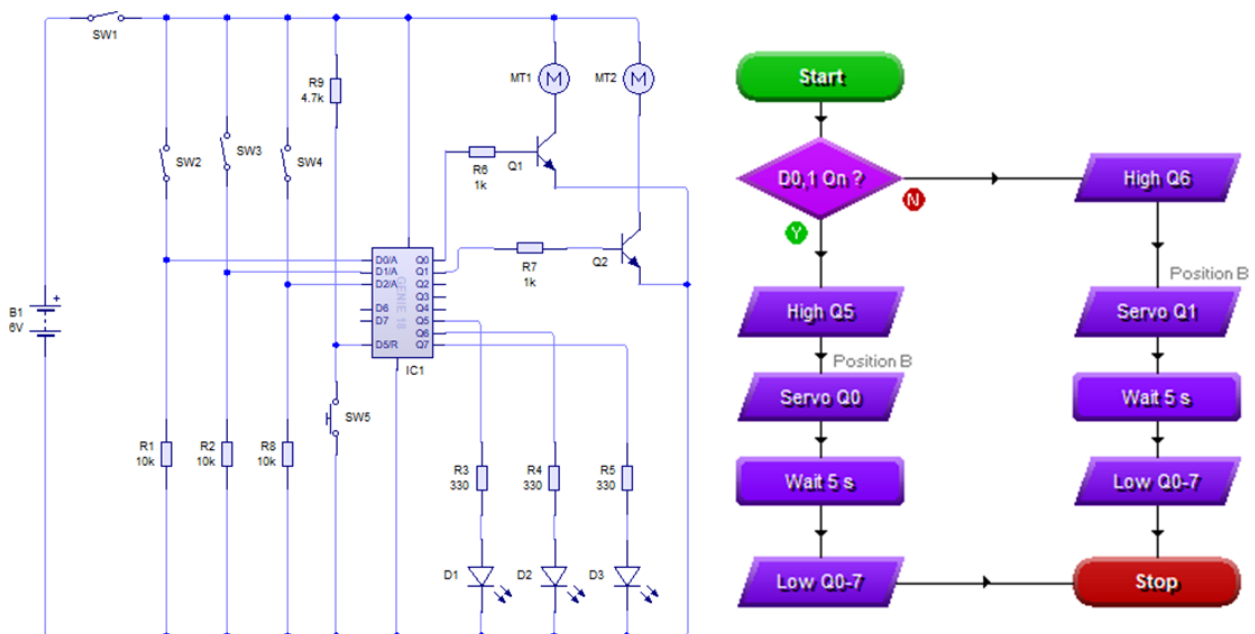

The outcomes of the simulation were as follows:

- When microcontroller inputs D0 and D1 were 'on' (representing the boxes being smaller than the values given in the brief) a signal was produced to turn servo motor Q0 to position B (I can change this to whichever position is required in the final system) and to turn on LED D1. Although this simulated fine on the flowchart program, the motor on the schematic view did not however move to the correct position – this is not a huge problem as the brief only requires the production of the correct signals for the servo motors but will need some further investigating.
- After this there was a delay of 5 seconds before all outputs were turned off and the outputs are reset back to their original state.
- When microcontroller inputs D0 and D1 were 'off' (representing the boxes being larger than the values given in the brief) a signal was produced to turn servo motor Q1 to position B and to turn on LED D2.
- After this there was again a delay of 5 seconds before all outputs were turned off and the outputs were reset back to their original state.
- The reset switch (SW5) worked as expected to terminate the current actions of the system and return it back to its original state.

I think to solve the issue regarding the servo motors outlined above, it would be better to use a dedicated Darlington motor driver IC rather than separate transistor-based Darlington pairs, and I will make this change on the PCB itself.

Overall, this simulation showed that the required servo motors will be able to turn to the correct positions to move the boxes, and the associated LED indicators will light up, depending on the sensor inputs. It also showed that this system can produce the signals required for the servo motor by using the 'Motor' output command, setting this to the 'servo' setting and selecting what position the motor needs to move to.

Commentary

The candidate has produced a basic, but functional, simulation of both the hardware and software aspects of their design using appropriate CAD software. The candidate has demonstrated a logical, but basic approach to developing a circuit that allows the schematic to be tested. They have tested the operation of the sensors, LEDs and servo motors using a flowchart program that mimics the operation of each.

They have also attempted to run this simulation on the circuit schematic itself, mainly successfully but with some issues found if the design is to fully meet the design criteria. They have described the findings of their simulation and outlined areas for improvement from this. For example, changing the drivers from discrete components to an integrated circuit with dedicated motor driver functionality.

In order to develop, the candidate could have produced a more detailed simulation that tested all aspects of the system. For example, they could have simulated the operation of the holding area sensor, and the associated LED and buzzer requirements from the original design criteria.

1d) Records of the results of testing the physical model of the circuit

Candidate evidence

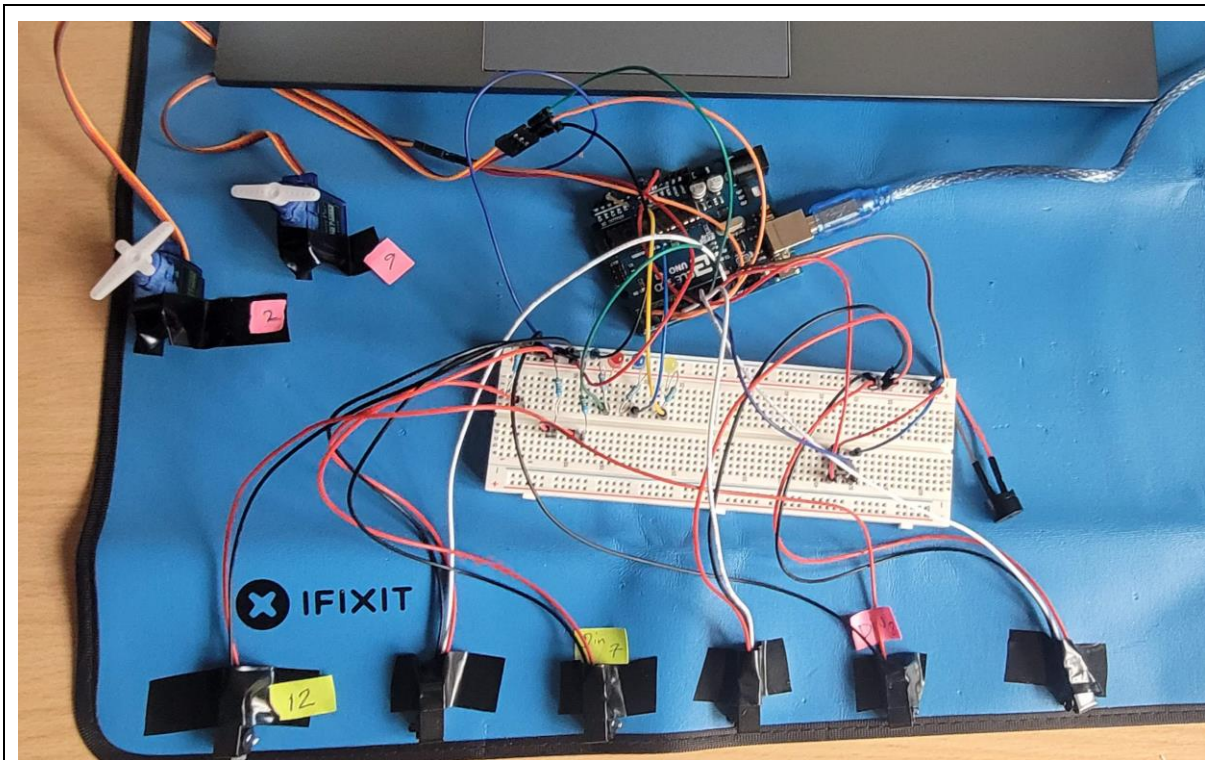

The use of an Arduino kit has been used to prototype the system.

This shows:

- 3x LEDs
- 1x Buzzer
- 3x IR Beam
- 1x push switch
- 6x resistors

All have been laid out in a logical way and the system was tested to prove it would work.

I used the Arduino Uno R3 project kit to produce a physical model of my circuitry. I had to build the kit using the appropriate sensors and servo motors, using a breadboard and placing the IR break beam sensors at an appropriate distance, to enable signal. These require to be mounted at the correct height in order for the system to operate as intended.

code | Arduino 1.8.12

File Edit Sketch Tools Help



code

```
int IRSensor = 2; // connect ir sensor to arduino pin 2
int LED = 13; // conect Led to arduino pin 13

void setup()
{
|

  pinMode (IRSensor, INPUT); // sensor pin INPUT
  pinMode (LED, OUTPUT); // Led pin OUTPUT
}

void loop()
{
  int statusSensor = digitalRead (IRSensor);

  if (statusSensor == 1)
    digitalWrite(LED, LOW); // LED LOW
  }

  else
  {
    digitalWrite(LED, HIGH); // LED High
  }
}
```

Using Arduino coding, I wrote a program to complete the system operation. I tested this for errors before plugging into a laptop and making the system run.

I found, similarly to my virtual model, that the IR sensors produced the correct digital input signals to the microcontroller, allowing it to produce the required output signals for the LEDs and servo motors to operate as required. Although the system was programmed to produce the correct servo motor PWM signals, the physical motors did not always turn as expected. This may indicate a fault in the model or an undiagnosed issue in the programming, which I will need to investigate and change on the final system.

Commentary

The candidate has produced a physical model that is mainly appropriate to reflect the proposed design criteria. The candidate has successfully modelled the operation of the IR sensors, LEDs and ICs producing the signals for the servo motors. The modelling was generally accurate but identified that some modifications would be needed to ensure all of the design criteria are met. For example, although the correct servo motor signals appeared to be sent via the microcontroller, the motors themselves were not turning to the correct angle. In addition, the model does not contain the audible output required for the box arriving in the holding area.

In order to develop their response, the candidate could have explained not only that some modifications are required, but also how these would be achieved and included a plan. They could also have included more detail about the process they used to test for errors.

1e) Bill of materials

Candidate evidence

I have compiled the following Bill of Materials. This outlines all of the materials and components that will be required to make the circuit.

Component	Cost per unit £	Quantity	Total cost £
6 V power supply	3.50	1	3.50
Infra-red beam sensor	3.99	3	11.97
10 K resistor	0.05	3	0.15
4.7 K resistor	0.05	1	0.05
Push button switch	0.18	1	0.18
18 pin PIC	3.60	1	3.60
330 ohm resistor	0.05	3	0.15
Green LED	0.09	1	0.09
Red LED	0.09	1	0.09
Yellow LED	0.09	1	0.09
Buzzer	1.12	1	1.12
Darlington pair IC	1.12	1	1.12
Solder reel	3.00	1	3.00
Multi-strand wire reel (red, black and blue)	6.00	2	12.00
Total cost			£37.11

Commentary

The candidate has produced a basic bill of materials that includes the main materials and components required to make the circuit. Appropriate quantities have been listed and approximate costs calculated.

To develop further, the candidate could have considered the components identified in more specific detail. For example, stating the exact Darlington driver IC used, such as a ULN2803, and the exact size of wire reels required to reduce the chance of waste. They could also have taken into account the potential need for block screw connectors for attaching input and output components and sockets for the ICs.

Task 2 – Manufacture and test

(Assessment themes: Health and safety, Manufacturing, Reports)

For task 2, candidates need to produce the following pieces of evidence:

- a) risk assessment
- b) PCB
- c) prototype
- d) test records for the results of testing the circuitry.

- Assessor observation of:
 - the production of the PCB
 - building of the soldered prototype
 - testing of the circuitry.

Photographic evidence which shows:

- unassembled PCB clearly showing the track layout (photographs 1-4)
- back of the assembled PCB showing all soldered joints (photograph 6-7)
- front of the assembled PCB showing positioning and fitting of components (photographs 5, 8-10)

Video evidence which shows:

- functionality of the prototype.

2a) Risk assessment

Candidate evidence

Hazard(s)	Risk(s)	Control(s)	Likelihood	Severity
Working area when designing, building and testing the prototype circuit	Slips, trips and falls.	Ensure area is clean and tidy.	1	1
Manual handling of tools and equipment	Back injury.	Do not lift over maximum lifting limit.	1	1
Working with stored electrical energy when building the prototype circuit	Burns, electric shock.	Ensure all stored energy is safely discharged.	3	2
PCB production for the prototype circuit	Impact injury from flying debris from milling machine.	Ensure machine guards are down and locked before use.	3	3
Use of soldering equipment for building the circuit	Burns, electric shock.	Keep hands away from tip of soldering iron. Wear safety glasses.	3	2
General use of hand tools and test equipment	Cuts, abrasions, general hand injury.	Ensure proper use.	1	1
Use of low voltage electricity for the PCB	Electric shock.	Ensure proper use. Disconnect power supply.	3	2
Equipment malfunction/faulty components	System heating up when working on it.	Check equipment before use. Ensure proper use. Disconnect power supply.	2	2

Likelihood		Severity	
1	Very unlikely to happen	1	Minor injury
2	Unlikely to happen	2	Major injury
3	Possible to happen	3	Loss of limb
4	Likely to happen	4	Death of an individual
5	Very likely to happen	5	Multiple deaths

Commentary

The candidate has considered and identified hazards and risks associated with the development of the prototype to ensure safe working is followed. To develop the response further, the candidate could categorise each element of the activity and identify hazards for each part, demonstrating a deeper understanding of risks and hazards in the workplace to ensure the safety of themselves and others. For example, the specific hazards related to the different stages of soldering – safe storage of solder, heating the soldering iron, applying solder to joints and extraction of fumes.

The control measures are appropriate, however lack detail, demonstrating the candidate may not have considered a variety of scenarios and situations that could arise during the making activities. They have demonstrated acceptable knowledge for risk mitigation techniques to work safely but would need to add further detail into their risk assessment to develop their response. For example, visual inspection of flex on soldering iron to check it is electrically safe prior to use.

The candidate has labelled the likelihood severity for each risk and hazard, with some accuracy. For example, electricity for the PCB is correctly identified as low voltage, with ratings of 3 for likelihood and 2 for severity. This demonstrates an acceptable standard of understanding and awareness of risk assessment and mitigation, and therefore safety to work. The candidate could have developed their response further by considering the likelihood/severity of all identified hazards and risks with a higher degree of accuracy. For instance, acknowledgement that risks may only cause minor injury, but would be of a higher likelihood rating (e.g. general hand tools and test equipment should be rated as 2 for likelihood, and 2 for severity, rather than 1 for both).

2b) PCB

Candidate evidence

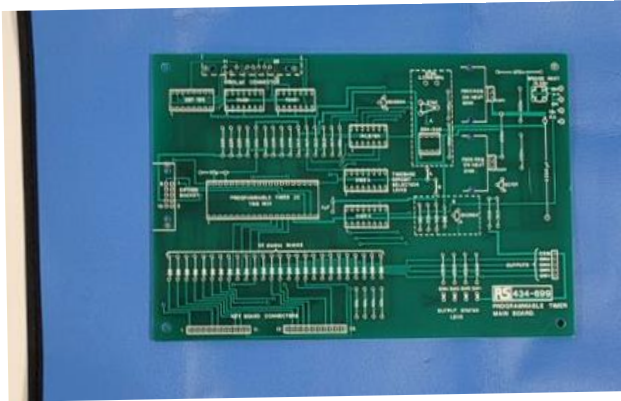

Front

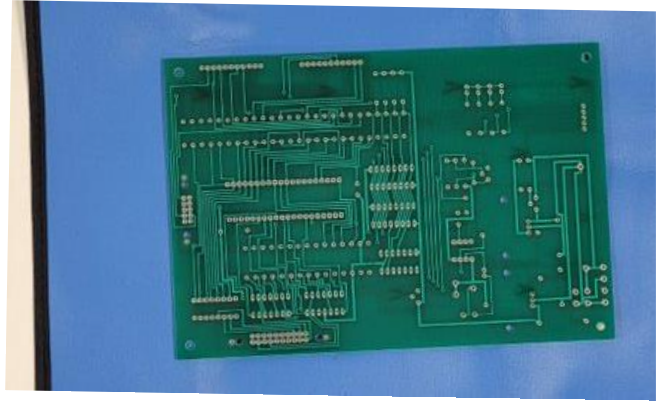

Back

Photographs 1 & 2 show the front and back side of the unassembled PCB including the track layout (note that the PCB pictured is not made to the exact specification of this assignment but is similar).

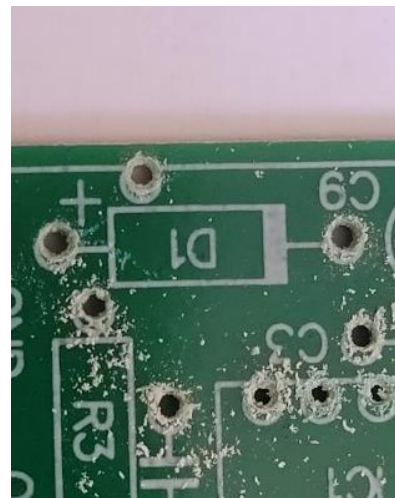

Photographs 3 & 4 show close ups of the drilling, which shows lack of precision. The candidate drilled holes manually in the correct locations, but some of the holes are not in the exact centre of each pad.

Practical observation form – PCB

Assessment ID	Qualification number
8714-322	8714-32
Candidate name	Candidate number
Candidate A	CG12345
Centre name	Assessment theme
City & Guilds	Health and Safety Manufacturing

Complete the table below referring to the relevant marking grid, found in the assessment pack. **Do not** allocate marks at this stage.

Task	Notes – <i>detailed, accurate and differentiating notes which identify areas of strength and weakness are necessary to distinguish between different qualities of performance and to facilitate accurate allocation of marks once all evidence has been submitted.</i>
PCB	<p>The candidate correctly exported their CAD file and program for manufacture to the CNC milling machine. They mounted the workpiece and secured it in the holders. They fitted the tool correctly but did not set the height accurately. They ensured the machine guards were down and locked before beginning manufacture and observed the milling process to ensure no safety issues arose during machining. Following machining, they removed the guard and the workpiece safely.</p> <p>The candidate then manually drilled holes in the correct locations for soldering components, but these were not always in the exact centre of each pad. They could have used the CNC machine to do this more accurately. They wore safety glasses whilst drilling and kept their hands away from the drill bit. Some dirt and debris were removed from the PCB, but some was left over.</p> <p>Although most steps were completed correctly and competently, some areas of copper were not fully routed, so although it will be functional if correctly assembled, the quality of finish is not high.</p>

Assessor signature	Date
<i>Assessor A</i>	03/04/2022

Commentary

The candidate demonstrated the ability to produce a PCB using the CNC milling process. The candidate completed each stage in a competent fashion and following a logical sequence. The candidate demonstrated understanding of each step of the process by completing each step and displaying that they knew what needed to be done at each stage. For example, the requirement to manually drill holes in order to solder.

The candidate followed the correct safety procedures throughout the task, such as ensuring all guards were in position and locked before use. Appropriate PPE was used to ensure safe working whilst drilling the holes in the PCB.

The output of the process was of a PCB that should be functional once assembled, but where improved care would have been resulted in a higher standard aesthetically. For example, the candidate could have shown greater accuracy and precision when drilling the holes for the components to be mounted into. In addition, the candidate could have set the height of the tool bit more accurately and cleaned the PCB more thoroughly in preparation for soldering.

2c) Soldered prototype

Candidate evidence

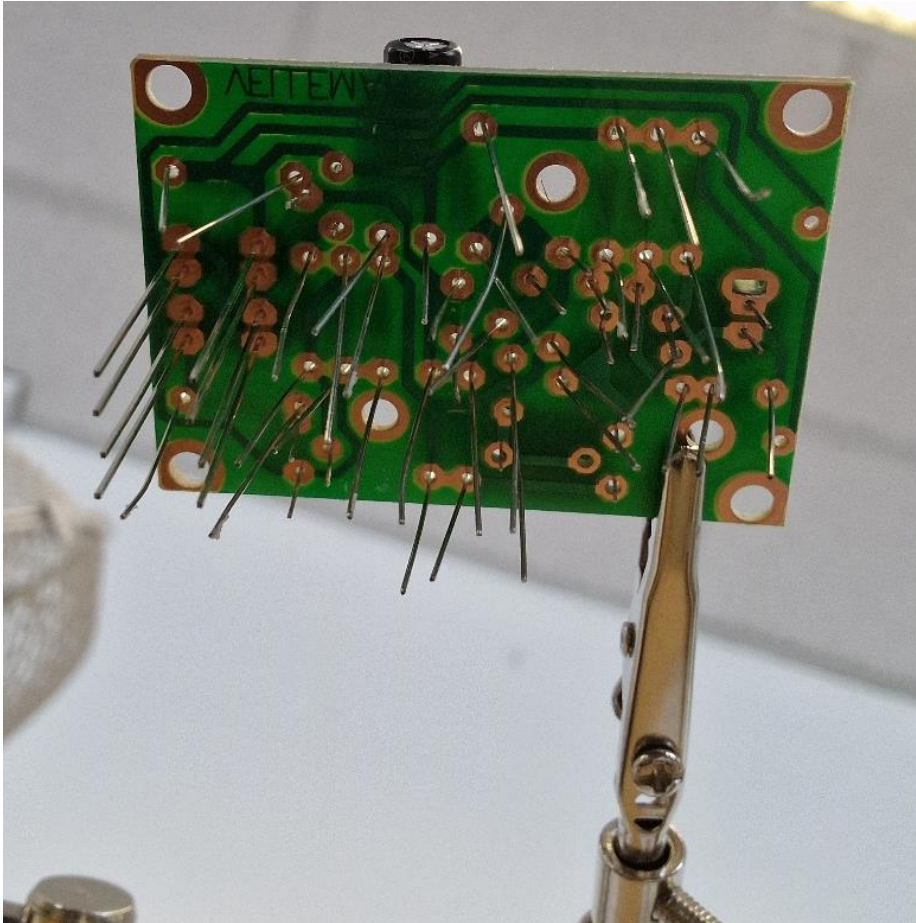

Photograph 5 shows the underside of the assembled PCB before soldering, to include positioning and fitting of components and demonstrating the quality of the routing. The components are placed correctly with the legs poking through correctly, although some are at different angles, which could lead to poor connection once soldered.

(Note that the PCB pictured is not made to the exact specification of this assignment, but is similar, intended to demonstrate the level of skill expected at threshold competence)

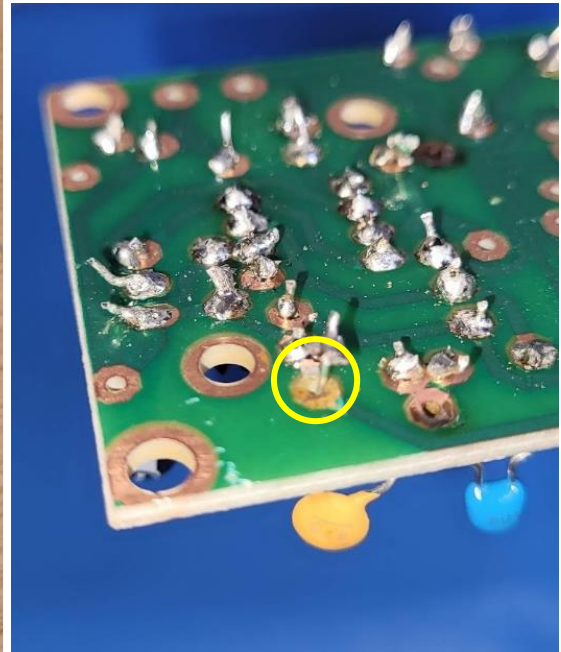
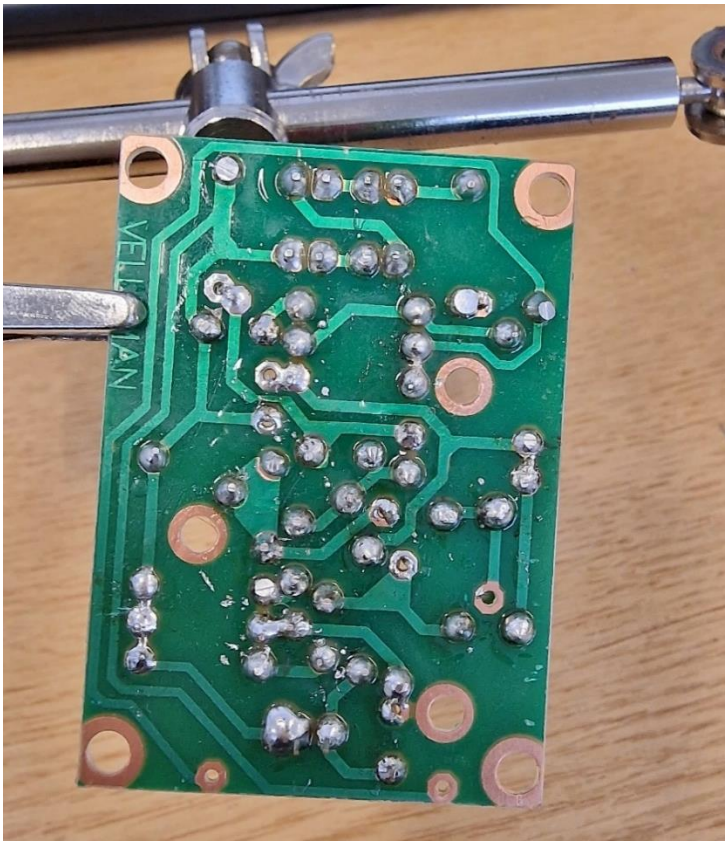

Photographs 6 & 7 show the back of the assembled PCB including all soldered joints. The soldering is messy, and some burning is observed, due to prolonged usage of the soldering iron. There is some evidence of not enough solder being used in some areas and too much solder used in other areas, creating a finish that is not very neat.

Photograph 7 shows some pad damage is visible (highlighted) because that leg was poorly soldered.

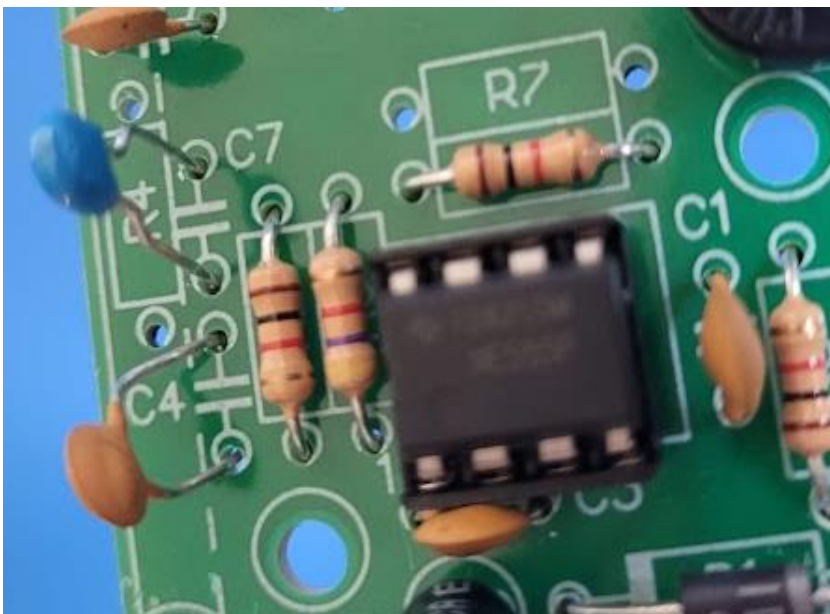
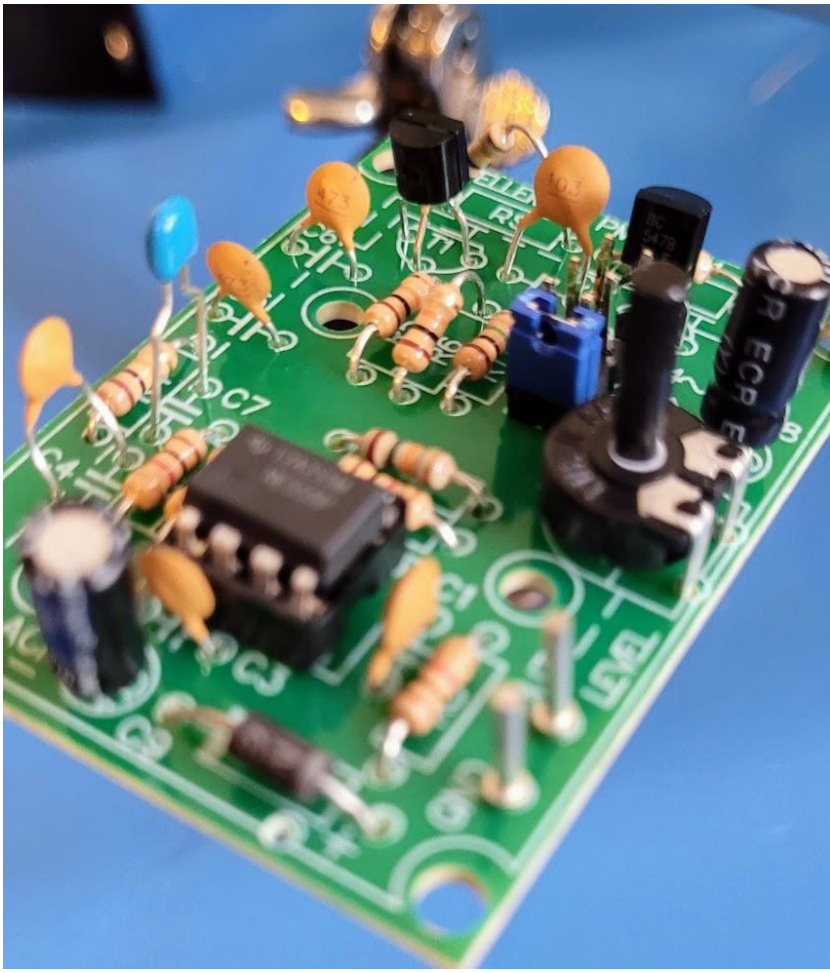

Photographs 8 & 9 show the top side of the assembled and soldered PCB including positioning and fitting of components. The components are placed correctly. A few of the capacitor legs have excessive length, but they are still functional.



Photograph 10 shows that the diode is fitted the wrong way round, with the wrong polarity. The candidate spotted and corrected this mistake as they progressed with the construction.

Practical observation form – Prototype

Assessment ID	Qualification number
8714-322	8714-32
Candidate name	Candidate number
Candidate A	CG12345
Centre name	Assessment theme
City & Guilds	Health and Safety Manufacturing

Complete the table below referring to the relevant marking grid, found in the assessment pack. **Do not** allocate marks at this stage.

Task	Notes – <i>detailed, accurate and differentiating notes which identify areas of strength and weakness are necessary to distinguish between different qualities of performance and to facilitate accurate allocation of marks once all evidence has been submitted.</i>
Construction of the prototype	<p>The candidate fitted the components into the holes of the PCB. This was not done in a fully logical order. Most components were fitted flush to the board, but the resistors were left slightly proud, leading to poor alignment of the legs, and poor soldering.</p> <p>The candidate used soldering equipment, including a soldering iron, stand and sponge, to solder the component legs to the pads on the PCB. They did not use aids such as pliers to assist with holding components in place whilst soldering. The soldering is adequate for functionality but could have been neater and more accurate. On some joints, too much solder has been used, creating visually messy joints and a poor quality of finish. The candidate wore safety glasses throughout the construction process and left the iron in the stand when not in use. Portable fume extraction was used throughout.</p> <p>The candidate fitted wires using block connectors and soldered joints. Wire strippers were used to remove insulation for wiring joints but too much insulation was removed from some wires, leaving some copper exposed. On some occasions, the candidate used wire strippers to cut wires to size, instead of using wire cutters. At one point the candidate fitted a diode incorrectly, with the wrong polarity, but they then spotted the mistake and rectified it unprompted.</p> <p>The candidate worked safely and wore appropriate PPE at all times. They followed all safe working procedures to ensure their own safety and that of others around them.</p>

Assessor signature	Date
<i>Assessor A</i>	03/04/2022

Commentary

Assembly processes were completed safely and with the correct PPE worn. For example, wearing safety glasses whilst soldering, using the stand when the iron was not in use and using portable fume extraction to avoid inhalation of solder fumes.

In order to develop further, the candidate could have been more careful and shown more accuracy when producing soldered joints and wiring connections. They could have used aids such as pliers to assist with holding the components in place during soldering, thus improving the quality of the joints produced.

The candidate has produced a fully soldered prototype that meets some of the needs of the design criteria. The quality of soldering is adequate for a functional circuit, but which would have benefitted from improved accuracy and consideration to a better quality of finish, for example, the use of too much solder on some joints, resulting in a messy outcome, and too much insulation being removed from the ends of some of the wiring.

2d) Testing

Candidate evidence

Test records

Design criteria	How this was tested	Test outcome
The circuitry must detect when the height of a box is less than 200 mm	I placed the IR sensors at appropriate positions on a test conveyor belt and sent boxes of different heights through.	The sensors detected the boxes that were too low - test passed.
The circuitry must detect when the length of a box is more than 300 mm	I placed the IR sensors at appropriate positions on a test conveyor belt and sent boxes of different lengths through.	The sensors detected the boxes that were too long - test passed.
The required accuracy of detection is within tolerance of 10% tolerance of the parameters stated	I calculated the maximum and minimum permissible values for length and height and checked these were being met during functional testing.	Test passed.
The maximum weight of the box is 2 kg	I used digital scales to weigh each box used during testing to ensure they were no heavier than 2 kg.	All boxes were 2 kg or lower in weight – test passed.
If the box is less than 200 mm high and 300 mm long, it must be directed down chute A. If it is larger than these sizes, it must be directed down chute B	I downloaded a test program in Circuits Wizard, using the 'Motor' command to test the operation the servos. This program produced the required PWM outputs, but the motors turned too far and did not always return to their original position as expected.	Test failed – some aspects of the test were successful, but ultimately the servos did not move to the correct positions when triggered or reset as expected.
The inputs to the circuitry must include: <ul style="list-style-type: none"> a method to turn the system on and off appropriate sensors to detect the required dimensions a sensor to detect when a product reaches the holding area 	I used a multimeter to check the voltage across the power switch when on and off. 0 V was recorded when off, 6 V when on. As explained above I functionally tested the operation of the sensors and these worked as expected.	On and off switch test passed. Sensor tests passed.
The outputs from the circuitry must include: <ul style="list-style-type: none"> a visual indicator (light) to indicate when a product should be directed down chute A a visual indicator (light) to indicate when a product should be directed down chute B appropriate output signals to operate the servo motors for the pivot arms, to both direct the boxes 	I functionally tested the LEDs for each condition and these lit as expected. A voltage drop of 2 V was measured across each LED. One LED did flicker until I realised there was a loose joint that I needed to repair. As explained above I downloaded a program to the microcontroller to provide the required PWM output signals. Oscilloscope readings showed these were as expected. However, the motors themselves did not respond as expected.	LED tests failed, but passed following remedial soldering work. PWM test only partially passed. Holding area test failed – no sound output.

<p>down the chute and to return to the start position as appropriate for the next box</p> <ul style="list-style-type: none"> • a visual indicator (light) and audible output to indicate when a product is in the holding area 	<p>I realised when testing that I had not included a buzzer or audible output for the holding area criteria. I was therefore unable to test this aspect of the circuit against the design criteria.</p>	
<p>The input and output devices should be connected to the circuitry</p>	<p>I visually checked the wiring connections were secure and used a continuity tester to ensure current flow through them.</p>	<p>Test passed – continuity confirmed by green LED on the tester.</p>

Practical observation form – Testing of the circuitry

Assessment ID	Qualification number
8714-322	8714-32
Candidate name	Candidate number
Candidate A	CG12345
Centre name	Assessment theme
City & Guilds	Health and Safety Manufacturing

Complete the table below referring to the relevant marking grid, found in the assessment pack. **Do not** allocate marks at this stage.

Task	Notes – <i>detailed, accurate and differentiating notes which identify areas of strength and weakness are necessary to distinguish between different qualities of performance and to facilitate accurate allocation of marks once all evidence has been submitted.</i>
Testing of the circuitry	<p>The candidate set up a test rig using a pre-assembled conveyor belt. They fitted their sensors and output devices to this and performed functional tests against each of the criteria in sequence. They tested against each of the initial design criteria and then the system as whole, but not against the additional requirements of the specification.</p> <p>They used functional tests to check the operation of the sensors and motors, passing boxes of different sizes through to ensure they were detected as needed. They used software testing by downloading a program onto the microcontroller to check the operation of the servo motors and the signals being sent to them and found issues with how these were working.</p> <p>They took measurements across the LEDs and checked for continuity across wiring connections using appropriate equipment. This took a few attempts to obtain accurate results, as in the first few instances the probes were incorrectly positioned on the circuit.</p> <p>Test equipment selected was used safely and mostly accurately. Some problems were observed when the candidate was downloading programs to test the production of output signals for the servo motors, resulting in potentially inaccurate test results.</p> <p>Test results were recorded mainly accurately but briefly in a test record sheet, showing general, but not in-depth results.</p>

Assessor signature	Date
<i>Assessor A</i>	03/04/2022

Commentary

The candidate demonstrated the ability to undertake basic testing of the circuitry against the requirements of the design criteria. The candidate selected some appropriate tests which allowed them to check that the requirements of some of the key design criteria had been met. For example, continuity testing of wires, functional testing of sensors and measuring the characteristics of the servo output signals using an oscilloscope. The candidate focused their testing activities on the main design requirements. In order to develop, the candidate could have considered the application of a wider range of test methods and tested against their full design specification.

Throughout the task, the candidate used test equipment safely and mostly accurately. Minor inaccuracies were noted, for example, when using test programs to check the output signals to the motors and their resulting functionality and needing more than one attempt to correctly position multimeter probes on the circuit.

The candidate completed a test record of the activity and their findings. The record covers all aspects of the criteria but is generally basic with minimal use of technical explanation. To develop their response, the candidate could have added more detail and depth to the methods used and results of each test undertaken, for example, the waveforms that were measured when testing the output signals, screenshots of the actual test programs downloaded and the exact positionings used for the sensor tests.

Task 3 – Peer review

(Assessment themes: Reports)

For task 3, candidates need to produce the following pieces of evidence:

- candidate notes on the candidate feedback record form

The candidate notes are not included in this document as the notes will vary from candidate to candidate and are not used to inform any other task.

- peer review feedback form.

This is supporting evidence for assessors to see what feedback the candidate received and how they used it in their review for task 4, and will not be marked.

Peer review feedback form

Candidate name	Candidate number
Candidate B	CG01234
Centre name	Centre number
City & Guilds	12345

Question	Feedback
How well does the design meet the requirements in the brief?	<i>I think the design is generally good. It meets most of the requirements of the brief. The sensors are detecting the size of the boxes and the LEDs are lighting up as needed. The motors are working when they should but don't always seem to move to the right positions. There is no audible output for when the box is in the holding area.</i>
How appropriate is the equipment proposed for the design?	<i>Tools and equipment used seemed to be generally appropriate. I think that Candidate A could have used a rule to more accurately measure out the lengths of wire needed before cutting them.</i>
What are the implications to the business of the proposed design?	<i>If there is no audible output to indicate when boxes have entered the holding area then workers might not notice this has happened. This could cause items that should have passed QC to end up not being distributed or sold, losing money for the business.</i>
How can the design be optimised / improved?	<i>I think you should add an audible output to the system, such as a buzzer, to warn when a box has entered the holding area. It can then be checked to see if it is of the correct size or sent down the conveyor again.</i>

Candidate name	Candidate number
Candidate C	CG012345
Centre name	Centre number
City & Guilds	12345

Question	Feedback
How well does the design meet the requirements in the brief?	<i>This is a good design overall. The sensors seemed to work well and detected when the boxes were not the right sizes. The LED lights lit up at the right time to indicate which chute the boxes were going down. I don't think the holding area control is working properly as I did not hear any sound output when a box was sent there. The LED lit up though.</i>
How appropriate is the equipment proposed for the design?	<i>I think the correct tools and equipment were used to make the prototype. Candidate A could have used pliers to hold components in place and make their assembly a bit neater. They could have used the CNC machine to drill the holes automatically, which would have made them more accurate.</i>
What are the implications to the business of the proposed design?	<i>If the circuit is not neatly made then it could break down in the future. This would cost money in downtime and maintenance to get it back up and running, and halt production. If no audible output is used in the holding area then this box could end up being forgotten about and lost, costing money in replacement.</i>
How can the design be optimised / improved?	<i>An audible output needs to be added when a box is in the holding area. This could be using an additional PCB so that the existing design does not have to be changed, or using screw connectors to one of the existing output ports on the PIC. <i>I would also add a voltage regulator IC to the front end of the circuit to ensure it is not damaged by any sudden changes in voltage from the power supply.</i></i>

Task 4 – Evaluation and implementation

(Assessment themes: Health and safety, Design and planning, Reports)

For task 4, candidates need to produce the following pieces of evidence:

- a) outcomes of virtual modelling
- b) revision control document
- c) evaluation and implementation report.

4a) Outcomes of virtual modelling

Candidate evidence

I used the same CAD software as before, Circuit Wizard, to produce an improved schematic model based on the feedback. I added an audible output as suggested for when a box enters the holding area. This is shown below, along with a test flowchart program to check that the buzzer works.

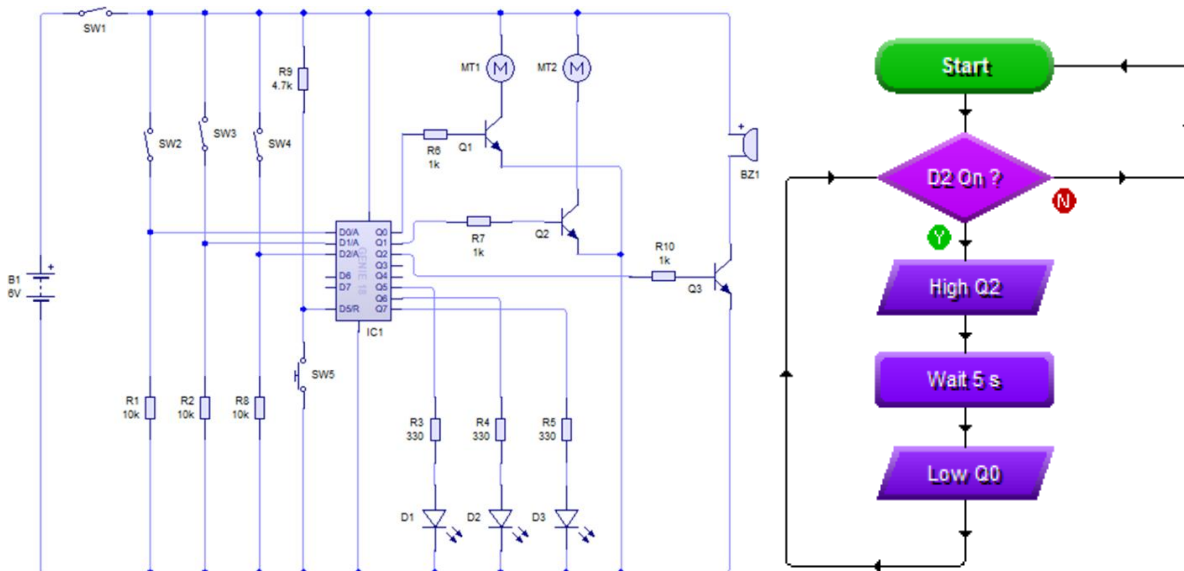

The buzzer is now connected to pin Q1 of the microcontroller. I added a transistor driver to ensure there was enough current to make it sound, as the PIC can only provide a few milliamps.

If the holding area IR sensor (D2) detects an item in the holding area, then the buzzer is turned on and sounds. This happens for 5 seconds before it turns off again. I can change the time it is on for depending on the requirements of the customer. This is an easy software change to make.

Commentary

The candidate has undertaken revisions to the original virtual modelling from task 1, demonstrating how they have considered the peer feedback they received in order to improve the design of the circuitry.

The model is basic but functional in its simulation of the hardware and software aspects of their design. They have connected a buzzer as it was recommended in the peer feedback, and they have also added a transistor driver to ensure it produces a noise.

In order to develop further, the candidate could have included more detail and annotations on the virtual model, and they could have highlighted the differences between the original and the updated virtual model, to explain their updates more clearly.

4b) Revision control document

System type	Conveyor belt sorting system
System TAG number	A1B2C3
Department responsible for equipment	Design and Development department
System designed by:	Candidate A

Design description:

This is a circuit to ensure the correct sizes of boxes moving down a conveyor belt move into the correct chutes depending on their lengths and heights. IR sensors have been used to achieve this. If some boxes are not detected or moved down the correct chute, they can end up in a holding area. At this point an LED lights up to show the box is in the holding area and needs attention.

Changes to existing system:

As shown in my virtual model above I added an audible output for when a box moves into the holding area. This was in response to feedback from both candidate B and candidate C, which I agreed with as it helps my design to meet the criteria more fully. I used a buzzer for this purpose.

Candidate B also mentioned the issue with the motors not always moving to the correct positions when triggered by the sensors. I was already aware of this problem and will try to update the programming on the microcontroller to adjust this.

Candidate C suggested adding a voltage regulator IC to the power supply section of the circuit. I have not added this to my design as I don't think changes in voltage would affect the operation of the circuit too much and it is therefore not necessary.

Changes to existing technical documentation:

The main changes that need to be made are to the circuit schematic and wiring diagrams. The schematic needs to be altered to add the buzzer connected, via a transistor, to port Q2 of the microcontroller. The wiring diagram would need to be changed to show how the buzzer is wired into the system. Multi-strand red and black wire would be used. Any records of the programs used with the PIC microcontroller will need to be updated as well.

Any technical manuals explaining the use of the system would need to be amended to include the additional circuitry. For example, where diagrams and instructions for use and maintenance are given within them.

The design criteria and specification do not need to be changed as these already had the criteria for an audible output given within them, but the previous version of the circuit was not meeting them fully.

Comments:

Overall, I am happy with the feedback received and have acted on the main points given by each candidate. I have suggested changes based on these that would help my design to meet the criteria more fully.

Validation performed by:	<i>Assessor 1</i>
Prototype approved by:	<i>Assessor 1</i>
Date:	16/06/2022

Commentary

The candidate has read and taken into account the feedback from both peer reviewers. They have responded to the feedback regarding the lack of an audible holding area indicator by adding a buzzer to the circuit schematic and simulating this in CAD software. They have correctly recognised that in order for this to be functional it would require a transistor to also be added as an additional driver stage to the system. To develop their response further, they could have acted more on the feedback regarding the motors and voltage regulators. They have stated that the inclusion of a voltage regulator as suggested is not necessary. Whilst not likely to be a large potential issue with the system, this would have been a technically sound addition, and would have added extra protection against potential future breakdown. Adding this would have shown greater technical understanding of the feedback made and its implications.

The candidate has produced a revision control document that covers the main requirements and documentation that would need to be updated. They have correctly identified that the schematics, wiring diagrams and any technical manuals would need changing. To develop their response, they could have explained how and why this needs to happen in more depth. For example, what specifically relating to the microcontroller program documentation would need to be changed and why is this important. They could also have suggested appropriate version numbers to use.

4c) Evaluation and implementation report

Evaluation –

I mainly used functional and software testing to check the function of my prototype. I used functional testing as it allowed me to see exactly how my prototype would function in the context of the actual production environment and on a model of an actual conveyor belt. Software testing was also very important because my proposed circuit is microcontroller-based. This means that the function of the circuit is dependent upon the operation of the programs downloaded and used. It was important to take measurements of the output signal voltages as these allowed issues to be found within the circuit and corrected before it is handed over to the client.

The circuitry was based around the use of an 18 pin PIC microcontroller. This allowed for in circuit programming and gave more than enough ports for the connections of input and output devices. Three infra-red sensor inputs, three LED indicator outputs and servos to control the movement of the boxes down each chute were also used. Power and reset switches were included to save battery power when not in use and allow for the user to restart the operation of the system at any given time. In future I may change these standard SPST and push switches to key switches, so that only authorised users can stop or restart the system.

Overall the circuitry meets most of the design criteria. However, there are a few issues that would need addressing for it to fully meet the needs of the brief. The infra-red sensors worked well and were able to detect the boxes were of the correct sizes. The correctly coloured LEDs lit up when the boxes went into the different chutes (red for A, green for B). After peer feedback I was also able to add a buzzer as an audible input when a box enters the holding area. However this feature was only added to my improved schematic, not the current version of the completed prototype. I had some issues with getting the motors to move to the correct positions to direct boxes down the chutes. The programming appeared to be providing the correct PWM signals, so I am still unsure as to why this occurred. One possibility is faulty or loose wiring.

Implementation –

In order for a third party to implement the prototype they will need the following information and documentation:

- The initial design criteria from the brief and final design specification from task 1.
- The final circuit schematics, wiring diagrams and models from tasks 1 and 3.
- The printed circuit board (PCB) layout from task 1.
- Test programs to download onto the microcontroller.
- The risk assessment from task 2.
- Datasheet for the 18 pin PIC microcontroller used.
https://picaxe.com/docs/picaxe_manual1.pdf

There are a number of factors that need to be considered during implementation. The first of these is the cable types used to connect the infra-red sensors to the circuitry. These should ideally be multi-strand, rather than single strand wire, as this is less likely to break when moved or subject to mechanical stress. Some IR sensors come with these wires already attached. If not they would need to be soldered in place. They could be attached to the circuit with either block connectors, crimped joints or soldering. I would recommend soldering as it is a strong, permanent joint.

There are a number of health and safety issues that must be considered when implementing the prototype. Firstly, safe working practices must be followed when producing and assembling the PCB and PPE should be worn at all times. This includes safety glasses, overalls or aprons and use of extraction when soldering. When using a milling machine to produce the PCB, the guards should be down and locked to prevent injury from flying debris. When soldering the iron should be kept in the stand when not in use, regularly cleaned on the sponge and hands should be kept

away from the hot tip. IET wiring regulations (BS 7671) should be followed when fitting and attaching cables to the PCB. In particular those related to low voltage applications and circuitry. Care must be taken not to suddenly release stored electrical energy when the circuit is in use.

To improve the circuit I could sort the issues regarding the positioning of the motors. This may require further checks to the wiring connecting them to the circuit and the programming of the microcontroller itself. Peer feedback suggested I should add a voltage regulator IC but this would need quite a bit of modification to the PCB, so I would not recommend it at this point.

Commentary

The candidate has produced an evaluation and implementation report that contains some basic information relevant to the design and finished prototype. They have explained the test methods used and provided brief justifications for their use. They have also explained how their circuit meets the needs of the design criteria and described the improvements that need to be made to fully meet the design brief. To develop further they could have justified the improvements needed, such as why it is important for the servo motors to move into the correct positions for each box on the conveyor belt.

The candidate has provided a list of documentations relevant to implementation, indicating that they have some knowledge of their relevance and importance. However, their response could have been developed further with more detail provided on the reason why each document is required for a third party to implement, and the information within each document that is of particular relevance.

They have described the safe working practices that a third-party should follow when implementing the prototype but this, although technically accurate, lacks depth of explanation. For example, they have referenced the appropriate sections of the IET wiring regulations, but to develop further, could describe the exact requirements of these for implementation, including the needs for future maintenance and usage.

T-LEVELS



Institute for Apprenticeships
& Technical Education

The T Level is a qualification approved and managed by the Institute for Apprenticeships and Technical Education.

Copyright in this document belongs to, and is used under licence from, the Institute for Apprenticeships and Technical Education, © 2020. 'T-LEVELS' is a registered trademark of the Department for Education. 'T Level' is a registered trademark of the Institute for Apprenticeships and Technical Education. 'Institute for Apprenticeships & Technical Education' and logo are registered trademarks of the Institute for Apprenticeships and Technical Education.

We make every effort to ensure that the information contained in this publication is true and correct at the time of going to press. However, City & Guilds' products and services are subject to continuous development and improvement, and the right is reserved to change products and services from time to time. City & Guilds cannot accept responsibility for any loss or damage arising from the use of information in this publication.

The City & Guilds of London Institute. All rights reserved. City & Guilds is a trademark of the City & Guilds of London Institute, a charity established to promote education and training registered in England & Wales (312832) and Scotland (SC039576). City and Guilds Group Giltspur House, 5–6 Giltspur Street London EC1A 9DE

