

**Level 1 Functional Skills Mathematics  
SAMPLE PAPER 2**

**Duration: 25 minutes**

**Total marks: 15**

**SECTION 1 – CALCULATOR NOT PERMITTED**

Candidate name (first, last)

First

Last

Candidate enrolment number

Date of birth (DDMMYYYY)

Assessment date (DDMMYYYY)

Centre number

Candidate signature and declaration\*

**\*I declare that I had no prior knowledge of the questions in this assessment and that I will not share information about the questions.**

**Please check that your name is correctly printed on the candidate barcode label. If not, please tell the invigilator before the start of the exam.**

**You should have the following for this assessment:**

- a pen with black or blue ink
- a pencil (for diagrams, graphs and charts only)
- an eraser
- a 30cm ruler
- a protractor.



**You must NOT use a calculator for Section 1.**

**General instructions**

- Read through each question carefully.
- Write all your answers in this booklet.
- Check your calculations and check that your answers make sense.

## SECTION 1 – CALCULATOR NOT PERMITTED

There are **15** marks available in this section.

You should check all your work as you go along.

You must **not** use a calculator in this section.



Q1

$846.7 \div 100 =$

\_\_\_\_\_

(1 mark)

Q2 The volume of this cuboid is  $24\text{cm}^3$ .

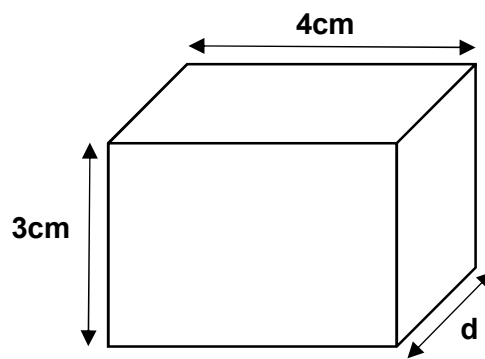

What is the value for the depth d?

\_\_\_\_\_ cm

(1 mark)

Q3

$9^2 =$

\_\_\_\_\_

(1 mark)

Q4

$18 - 5 \times 2 =$

\_\_\_\_\_

(1 mark)

Q5



A

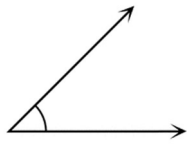

B

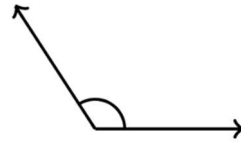

C



D

Which of the above has an angle of  $180^\circ$ ?

(tick one box)

A

B

C

D

(1 mark)

Q6

Write two hundred and forty-six thousand eight hundred and five in figures

\_\_\_\_\_

(1 mark)

Q7

What is  $\frac{2}{5}$  as a decimal?

(tick one box)

A 0.4

B 0.2

C 0.25

D 0.04

(1 mark)

**Q8**

$-6 + 4 =$

*(tick one box)*

**A**      -10

**B**      - 2

**C**      2

**D**      10

**(1 mark)**

**Q9**

What is the range of these weights?

**40 kg 65kg 27kg 84kg 34kg**

\_\_\_\_\_ kg

**(1 mark)**

**Q10** At a rugby match 19 417 home fans and 2 648 away fans attend.

What is the total attendance, rounded to the nearest hundred?

\_\_\_\_\_

**(1 mark)**

**Q11** A company conducts a survey. The survey asks people their ages.  
The data will be grouped.

Complete the table with the missing age groups.

Age group boundaries
25 and under
26 - 35
46 - 55
65 and over

(1 mark)

**Q12** A manager wants to know the ratio of men to women in their factory. There are 135 men and 270 women working at the factory.

What is the ratio of men to women?

\_\_\_\_\_ : \_\_\_\_\_

(2 marks)

**Q13** A fair has a spin the arrow game.  
A player wins a prize if the arrow lands on a 5.

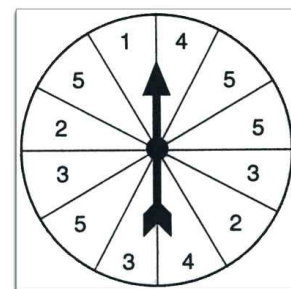

What is the probability of a player winning a prize?  
Write your answer as a fraction in its simplest form.

(2 marks)

**End of Section 1**